

# 54350

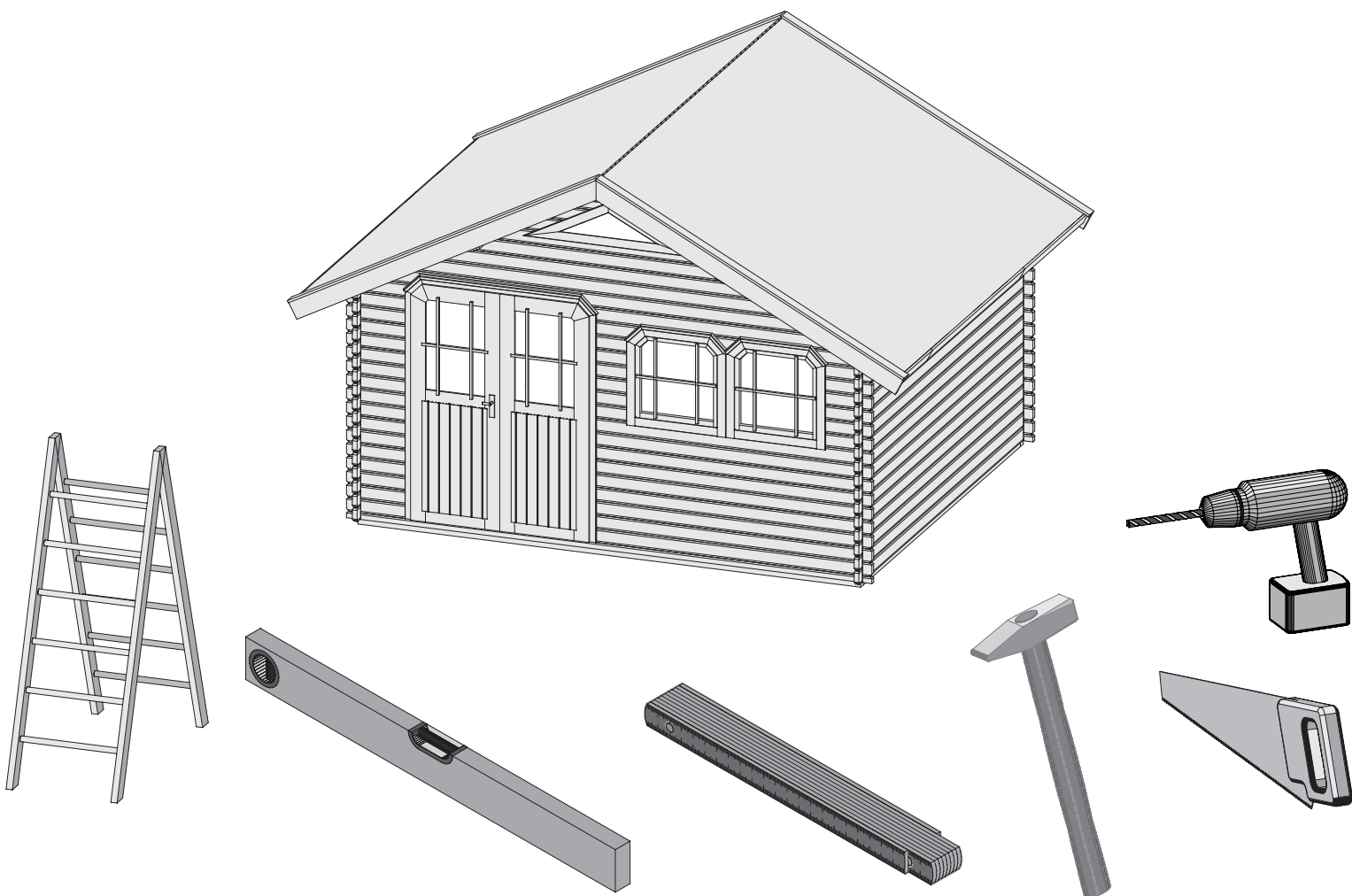

 **Aufbauanleitung**

 **notice de montage**

 **Building Instructions**

 **montagehandleiding**

 **Instrucciones de construcción**

 **Istruzioni per il montaggio**

 **Service-Hotline: +49 421 38693 33**



Vergleichen Sie zuerst die Materialliste mit Ihrem Paketinhalt! Bitte haben Sie Verständnis, dass Beanstandungen nur im nicht aufgebauten Zustand bearbeitet werden können!



Commencez par comparer la liste du matériel avec le contenu de votre paquet! Sachez que nous traitons uniquement les réclamations concernant le matériel à l'état non monté!



First compare the list of materials with your package contents! Please understand that complaints can be processed in the non-built status only!



Vergelijk eerst de lijst van materialen met de inhoud van uw pakket! Reclamaties kunnen alleen in behandeling worden genomen zolang de onderdelen nog niet zijn gemonteerd!



En primer lugar, compare la lista de material con el contenido del paquete. Rogamos entienda que las reclamaciones sólo pueden ser tramitadas antes de montar el objeto!



Confrontate questa distinta materiali prima con il contenuto del pacchetto! Vi preghiamo di comprendere che eventuali reclami possono essere accolti solo prima del montaggio!



54350

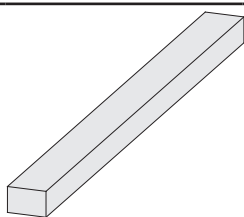

|         |                  |          |
|---------|------------------|----------|
| 1 x A1  | 1515 x 45 x 18mm | ID 21585 |
| 4 x A2  | 2100 x 45 x 18mm | ID 19547 |
| 5 x A3  | 1940 x 95 x 18mm | ID 15495 |
| 4 x A4  | 2750 x 95 x 18mm | ID 42095 |
| 2 x A5  | 400 x 120 x 18mm | ID 21291 |
| 12 x A6 | 250 x 140 x 26mm | ID 21602 |
| 1 x A7  | 625 x 38 x 28mm  | ID 42302 |
| 4 x A8  | 3990 x 60 x 40mm | ID 28695 |

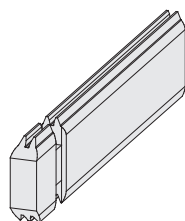

|         |                  |          |
|---------|------------------|----------|
| 6 x W5  | 381 x 121 x 40mm | ID 42298 |
| 16 x W6 | 485 x 121 x 40mm | ID 38777 |
| 10 x W7 | 2200x121x40mm    | ID 29548 |

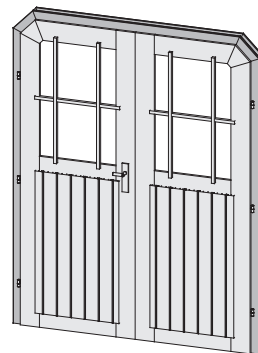

|        |          |
|--------|----------|
| 1 x D1 | ID 14157 |
|--------|----------|

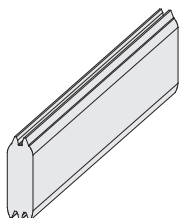

|        |                  |          |
|--------|------------------|----------|
| 6 x W1 | 272 x 121 x 40mm | ID 42299 |
|--------|------------------|----------|

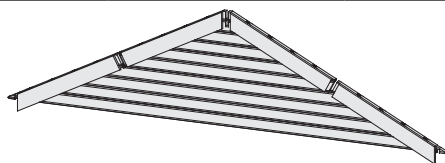

|        |                |          |
|--------|----------------|----------|
| 2 x W8 | 4140x1066x40mm | ID 29914 |
|--------|----------------|----------|

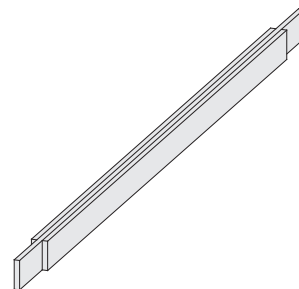

|        |               |          |
|--------|---------------|----------|
| 3 x M1 | 3920x140x78mm | ID 29911 |
|--------|---------------|----------|

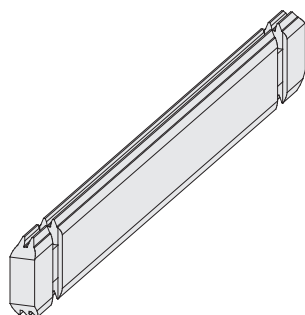

|         |                   |          |
|---------|-------------------|----------|
| 34 x W2 | 3570 x 121 x 40mm | ID 29485 |
| 18 x W3 | 4170 x 121 x 40mm | ID 23023 |

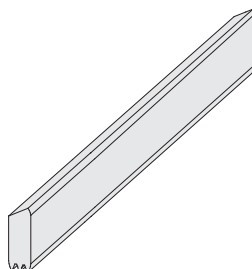

|        |                 |          |
|--------|-----------------|----------|
| 1 x G1 | 2500 x 113x40mm | ID 21030 |
| 1 x G2 | 2902 x 113x40mm | ID 29523 |

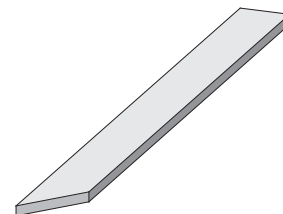

|        |               |          |
|--------|---------------|----------|
| 4 x Z1 | 2750x140x26mm | ID 49417 |
|--------|---------------|----------|

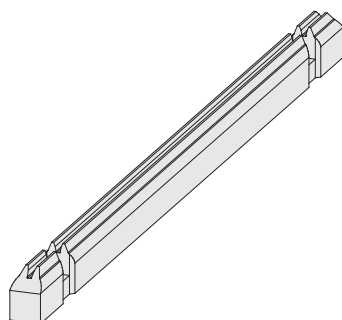

|        |                  |          |
|--------|------------------|----------|
| 2 x W4 | 4170 x 71 x 40mm | ID 29547 |
|--------|------------------|----------|

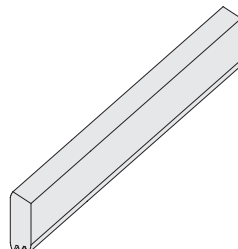

|        |                 |          |
|--------|-----------------|----------|
| 1 x G3 | 2500 x 113x40mm | ID 21031 |
| 1 x G4 | 2902 x 113x40mm | ID 29491 |

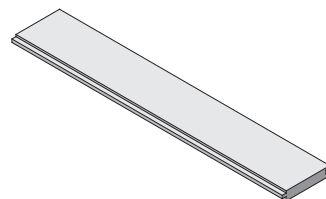

|         |                  |          |
|---------|------------------|----------|
| 90 x B1 | 2700 x 96 x 18mm | ID 19569 |
|---------|------------------|----------|

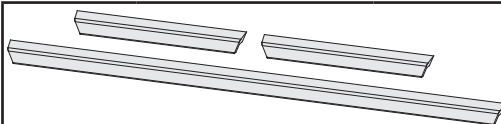

|        |                  |          |
|--------|------------------|----------|
| 4 x Y1 | 198 x 52 x 23mm  | ID 21324 |
| 2 x Y2 | 1304 x 52 x 23mm |          |
| 8 x Y3 | 198 x 52 x 23mm  | ID 21325 |
| 4 x Y4 | 580 x 52 x 23mm  |          |

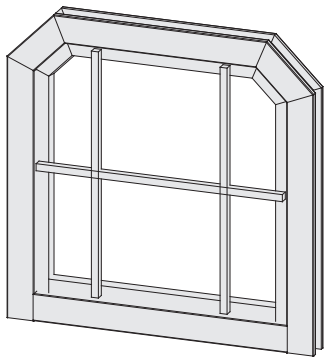

2 x

ID 13695

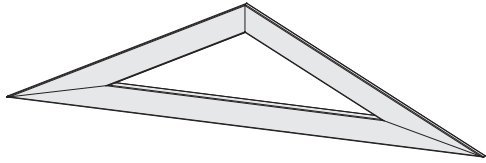

1 x

ID 21088

1 x



ID 16034

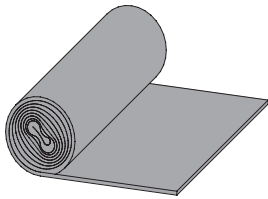

3 x

10m<sup>2</sup>

ID 37962



70 x

4 x 25mm

ID 5841

80 x

4 x 35mm

ID 3687

60 x

4 x 50mm

ID 3688

60 x

4 x 60mm

ID 21207

8 x

4,5 x 80mm

ID 9204

4 x

6 x 120mm

ID 9205



250 x

4 x 70mm

ID 39352

1000 x



ID 5621

300 x



ID 3949

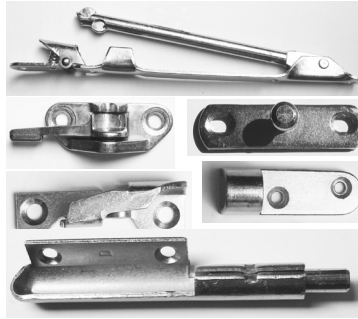

2 x

ID 16337



1 x

ID 15979

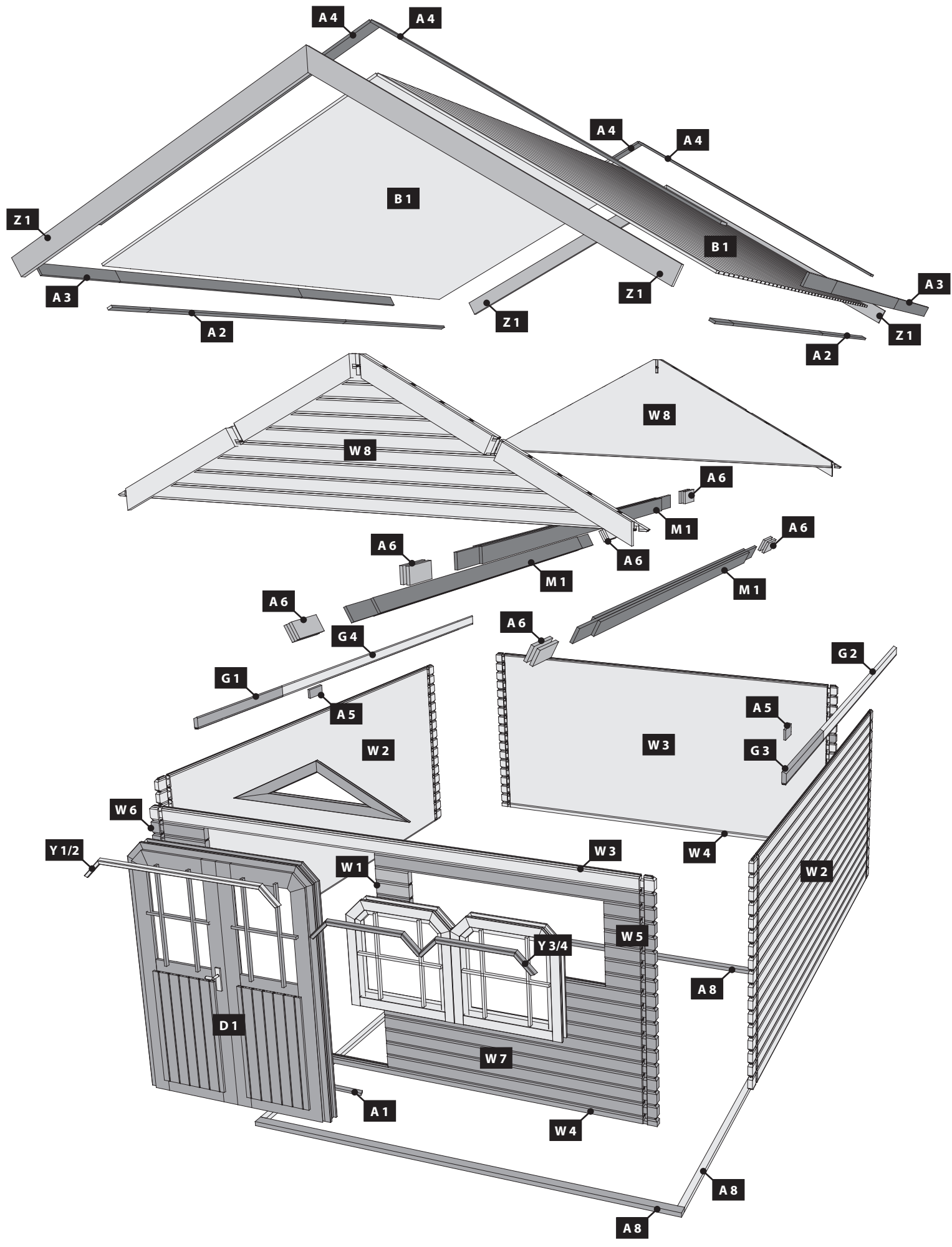

02 2x

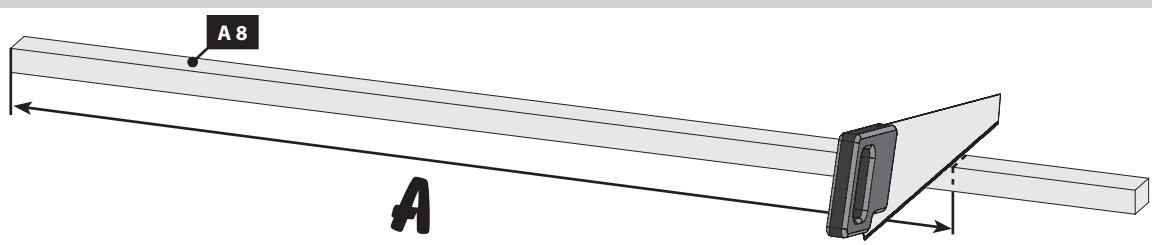

03

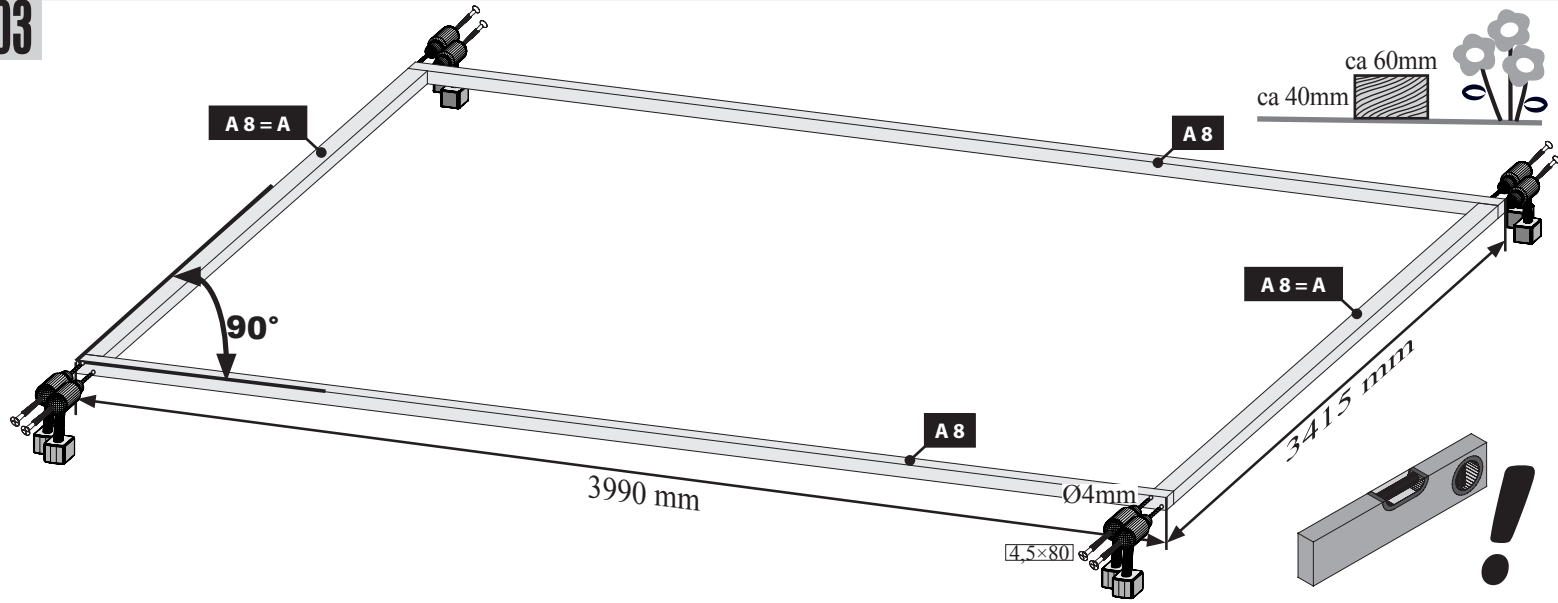

04

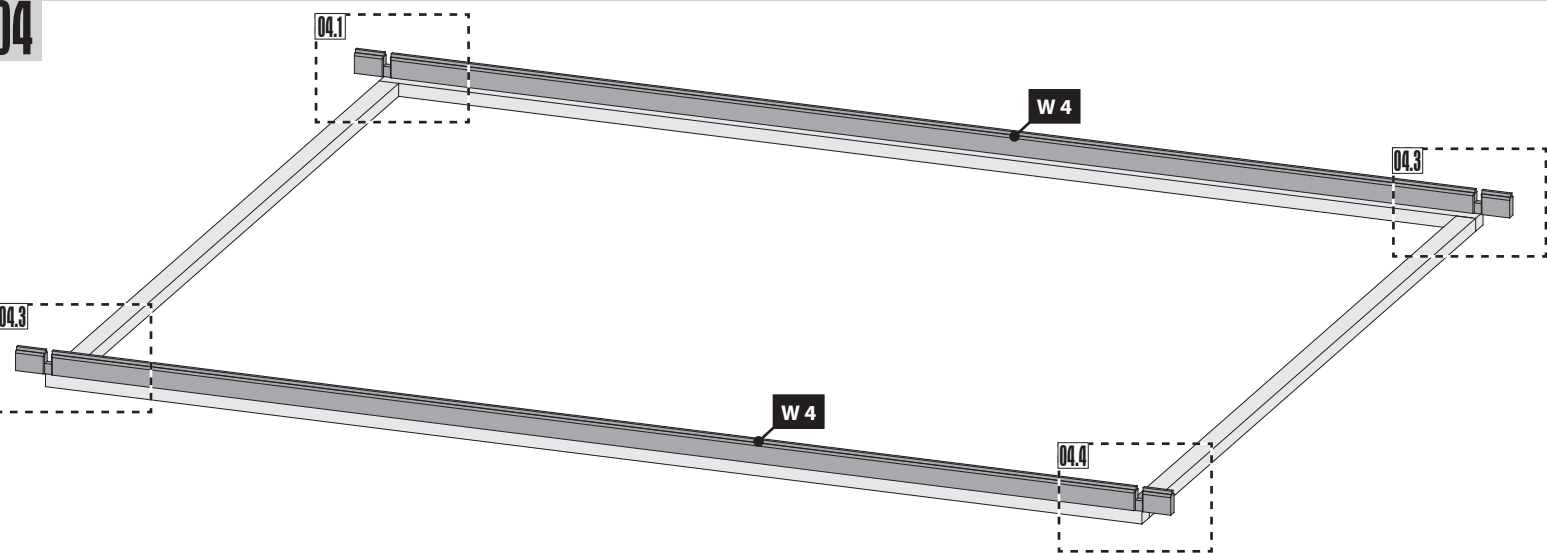

04.1

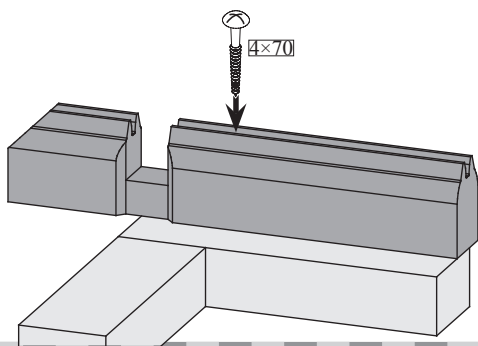

04.2

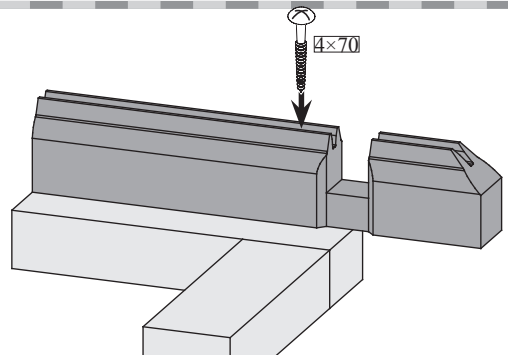

04.3

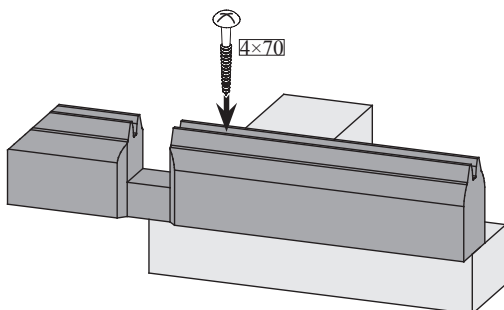

04.4

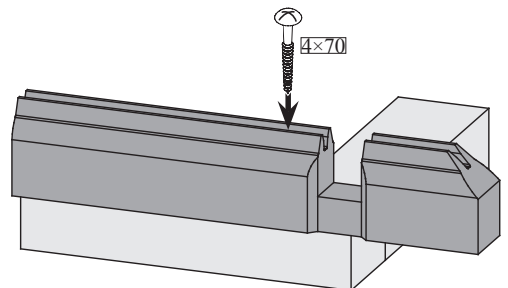



 Verschraubung Ausschnitte

 Cut-outs for screw connections

 Atornilladura recorte

 Vissage découpes

 Vastschroeven uitsparingen

 Fissaggio tavole

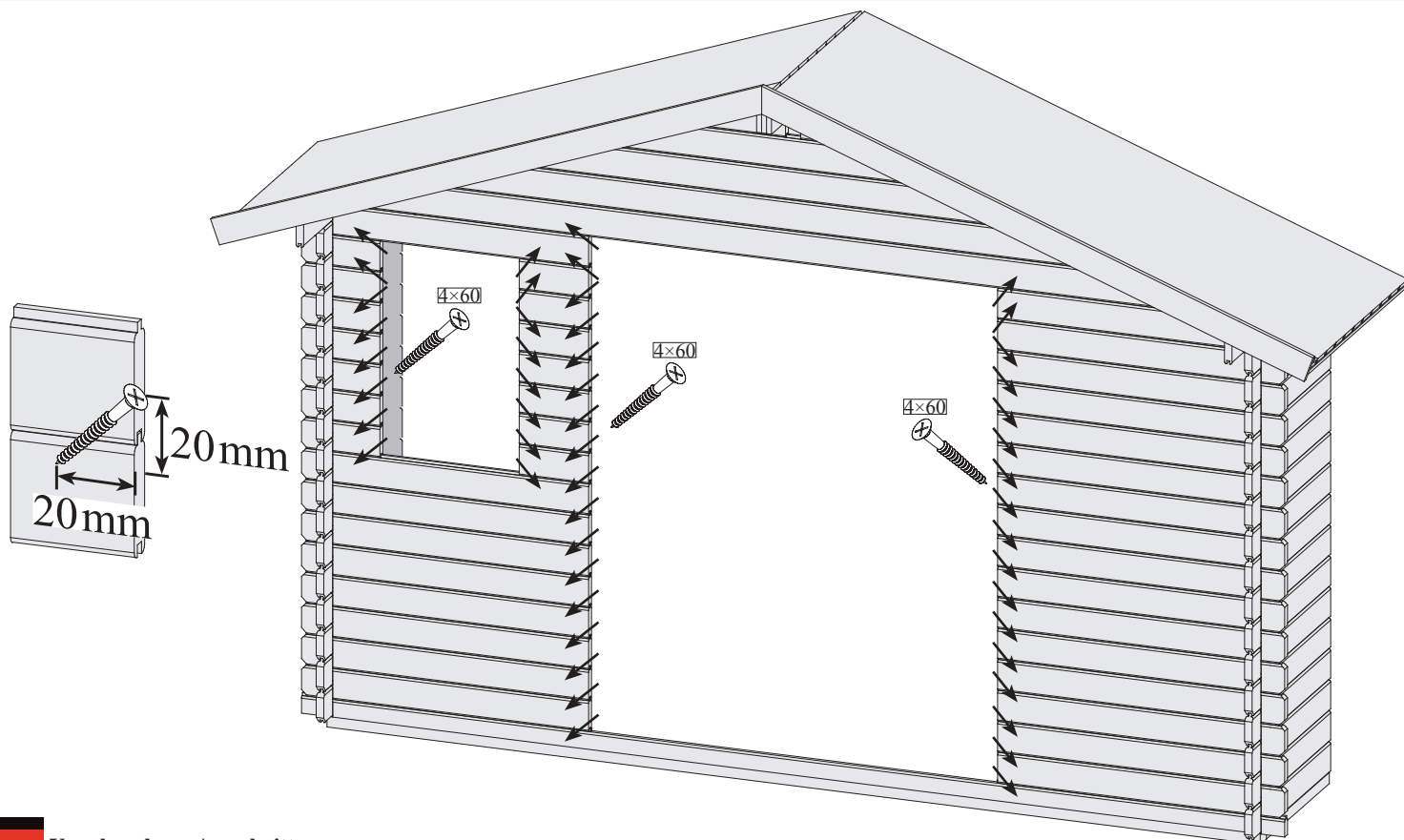

### Verschraubung Ausschnitte

Holz hat ein natürliches Quell und Schwindverhalten. Dadurch „wächst“ und „schrumpft“ Ihr Haus im Laufe eines Jahres. Kürzere Holzbohlen (Front) passen sich schneller als längere Bohlen den aktuellen klimatischen Bedingungen an. Dadurch kann es zu Spaltenbildungen kommen. Um diese Spaltenbildung zu verringern aber gleichzeitig das natürliche Quell- und Schwindverhalten des Holzes zu gewährleisten müssen Sie an Fenster und Türausschnitten die jeweils zwei direkt übereinandersitzenden Bohlen miteinander verbinden. Verwenden Sie dafür Spax 4 x 60. Bohren Sie die Bohlen bei einer Verschraubung immer vor. **Hinweis:** Schräge Bohrungen ohne Abrutschen: Die ersten 3 bis 5mm den Bohrer senkrecht zur Holzoberfläche ansetzen und erst dann im gewünschten Winkel bohren.

### Vissage découpes

Le bois a un comportement naturel de gonflement et de rétraction. C'est ainsi que votre pavillon «se gonfle» et «se rétracte» au cours d'une année. Les madriers de bois plus courts (façade) s'adaptent plus rapidement aux conditions climatiques que les madriers plus longs. Ceci peut entraîner des fentes. Pour réduire cette formation de fentes tout en garantissant que le bois puisse se comporter de manière naturelle, vous devez raccorder au niveau des fenêtres et des découpes de porte les deux madriers respectivement situés l'un sous l'autre. A cet effet, utilisez des Spax 4 x 60. Lors de vissages, veuillez toujours percer un trou préalable dans les madriers. **Remarque:** pour percer des trous inclinés sans dérapier, veuillez tenir la perceuse de manière perpendiculaire lors des premiers 3-5 mm, puis percer ensuite dans l'angle souhaité.

### Cut-outs for screw connections

Wood is subject to a natural process of swelling and contraction. For this reason, over the course of the year your house “grows” and “shrinks”. Shorter wooden boards (front) adapt faster than long boards to the momentary climatic conditions. This can result in cracking. In order to reduce this cracking and at the same time allow for the natural growth and shrinkage behaviour of the wood, at the window and door recesses you must join each two boards positioned directly over each other. For this purpose, use 4 x 60 Spax joints. Always pre-drill the boards for screw can drill obliquely into the wood without slipping connections. **Note:** You away by setting on the drill vertically for the first 3-5 mm and only then drilling obliquely.

### Vastschroeven uitsparingen

Hout zet uit en krimpt van nature. Daardoor zal ook uw huisje in de loop van een jaar „uitzetten“ en „krimpen“. Kortere houten delen (front) passen zich sneller danlangere delen aan de verschillende klimatologische omstandigheden aan. Daardoor kunnen er zich spleten vormen. Om de vorming van deze spleten te verminderen, maar tegelijkertijd het natuurlijke uitzet- en krimpedrag van het hout te waarborgen, moet u bij raam- en deuruitsparingen telkens de twee direct boven elkaar bevindende delen met elkaar verbinden. Gebruik daarvoor spax-schroeven 4 x 60. Boor de delen bij het vastschroeven altijd voor. **Opmerking:** schuin boren in hout zonder weg te glijden gaat het beste door de eerste 3-5 mm de boor haaks op de oppervlakte van het hout te houden en pas daarna onder de gewenste hoek te boren.

### Atornilladura recorte

La madera tiene un comportamiento natural de hinchamiento y encogimiento. Debido al mismo, su casa „crece“ y se „encoge“ a lo largo del año. Los tablones de madera cortos (parte delantera) se adaptan más rápido que los largos a las condiciones climatológicas. Para reducir esta formación de ranuras pero, al mismo tiempo, garantizar el proceso natural de hinchamiento y encogimiento de la madera, tiene que unir en la ventana y los recortes de la puerta entre sí los dos tableros que están justo uno sobre otro. Utilice para ello Spax 4 x 60. Perfore siempre previamente los tablones antes de efectuar el atornillamiento. **Advertencia:** Para efectuar perforaciones inclinadas en la madera sin resbalar hacer los primeros 3-5 mm con la broca vertical respecto a la superficie y después inclinar en el ángulo deseado.

### Fissaggio tavole

È naturale che il legno lavori dilatandosi e restringendosi. Per questo la vostra casa „cresce“ e „si contrae“ nel corso dell'anno. Le assi più brevi (quelle frontali) si adattano alle situazioni climatiche più velocemente di quelle più lunghe. Per questo si può avere la formazione di crepe. Per minimizzare il rischio della formazione di crepe ma allo stesso tempo per permettere le contrazioni e dilatazioni del legno, sulle aperture della finestra e della porta collegare le due assi direttamente in contatto tra loro. Utilizzare a tal fine viti a croce da 4 x 60. Preforare sempre le assi prima di avvitare. **Avviso:** Per fare dei fori obliqui nel legno senza che la punta scivoli si può dapprima fare un foro perpendicolare per 3-5 mm e poi iniziare a forare con l'angolo desiderato.

08

!!! A=B !!!

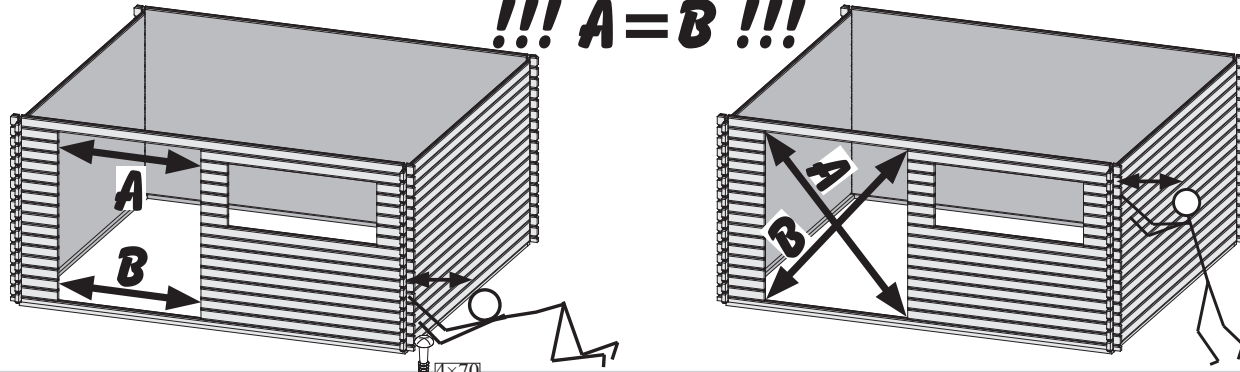

09

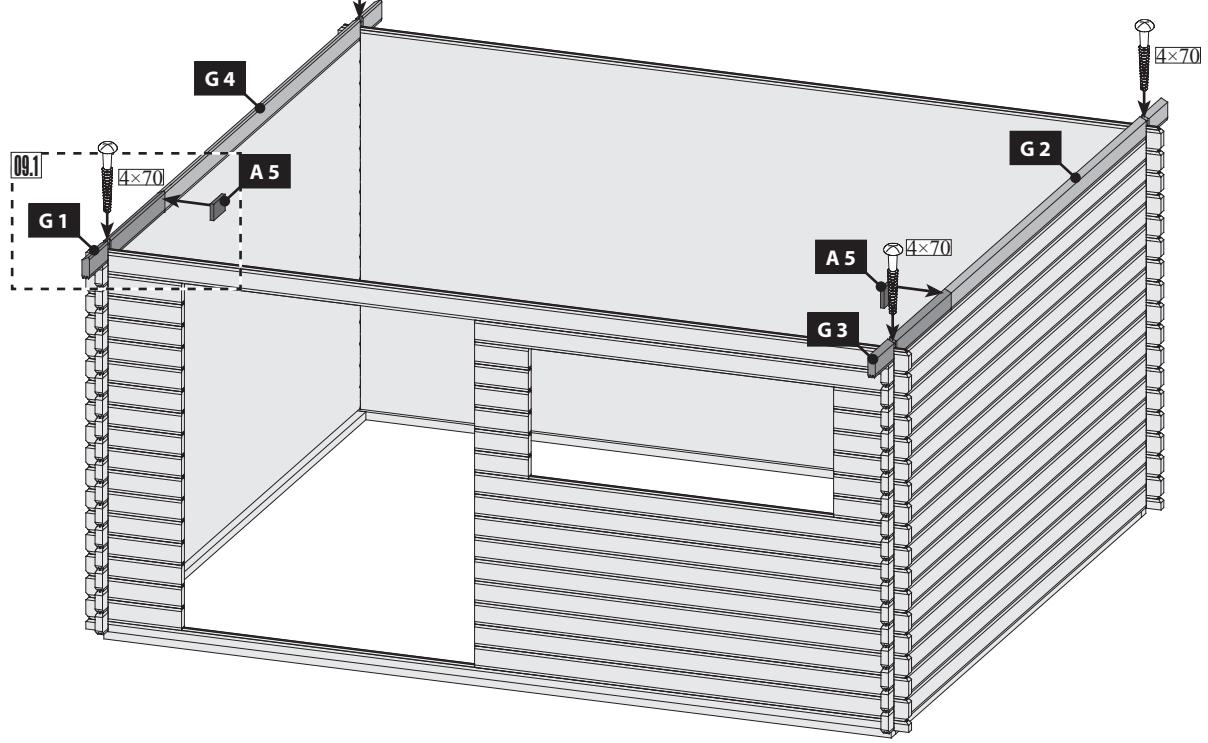

09.1 A

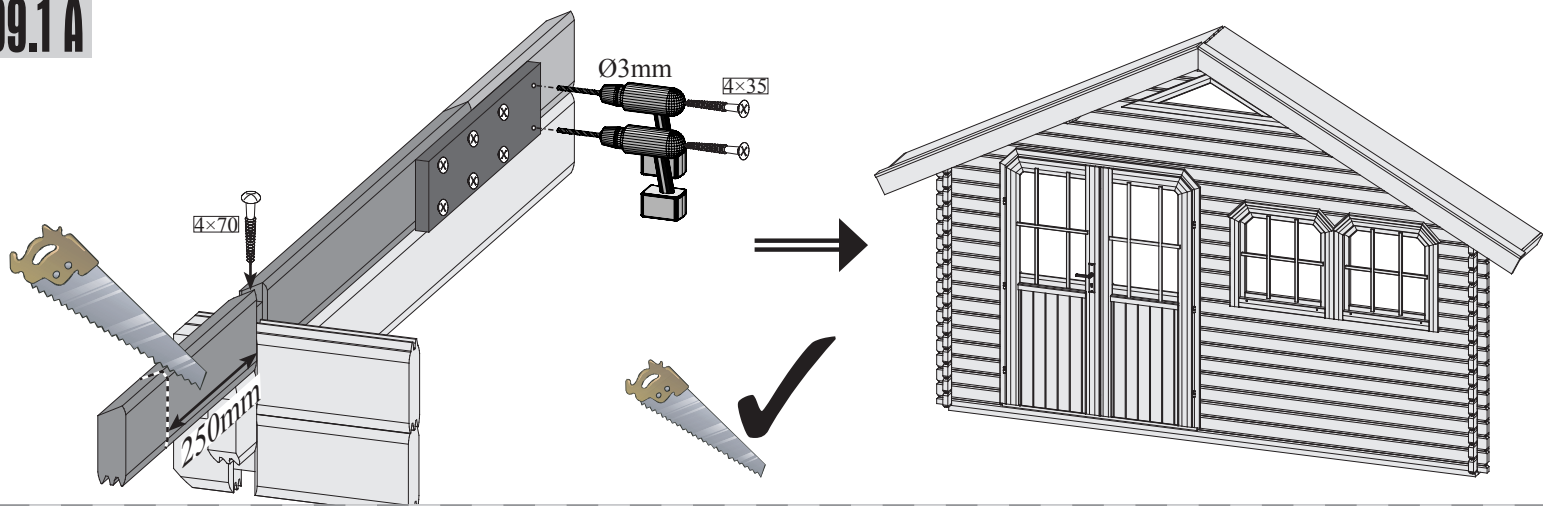

09.1 B

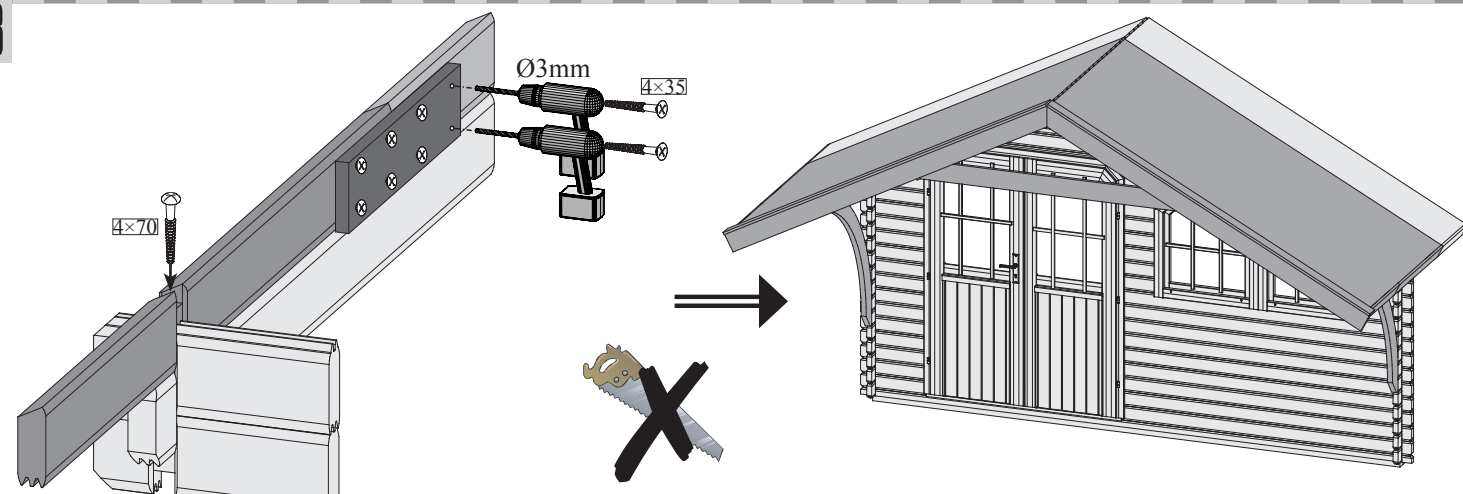

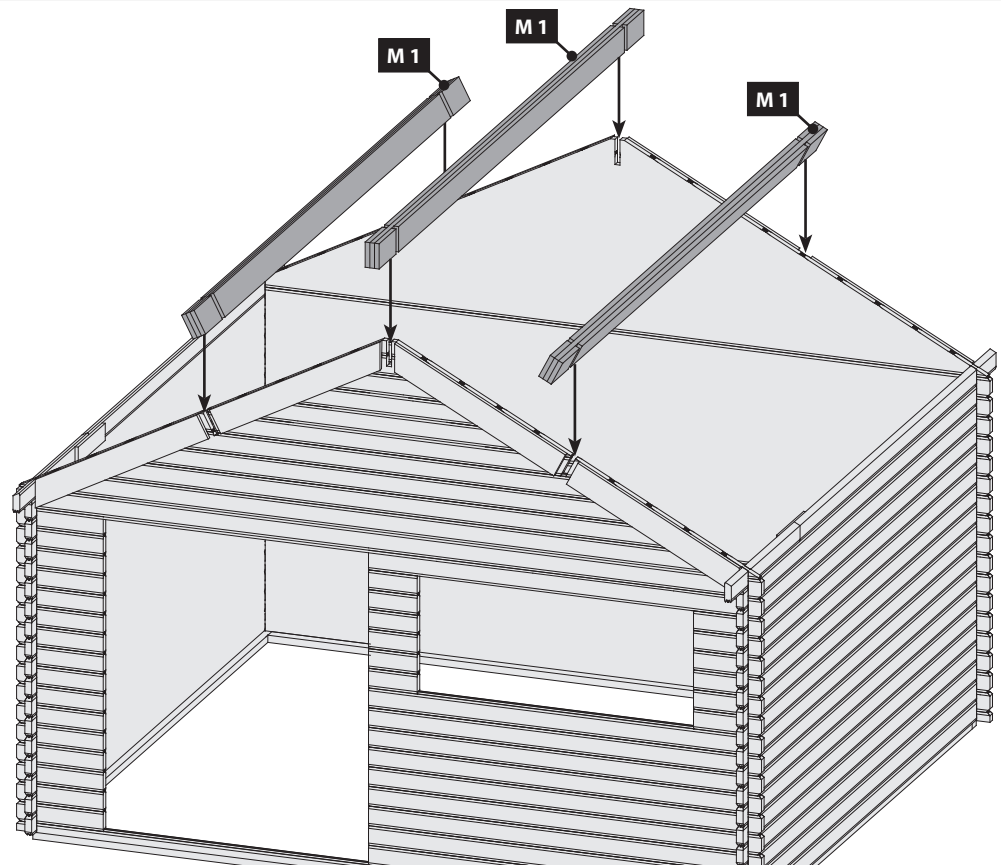
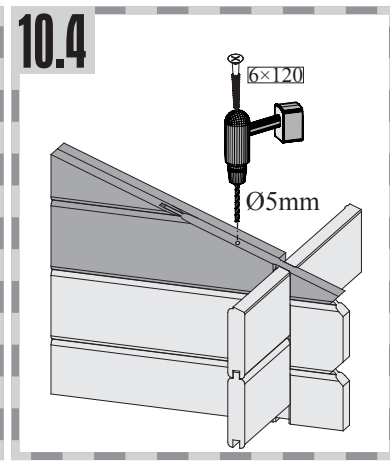
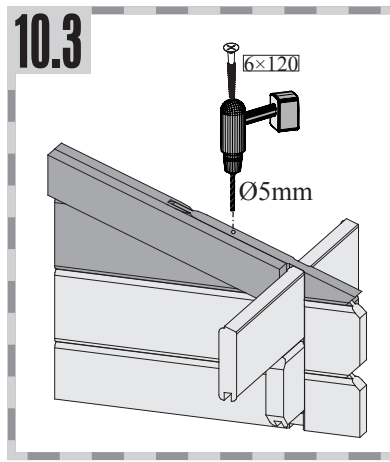
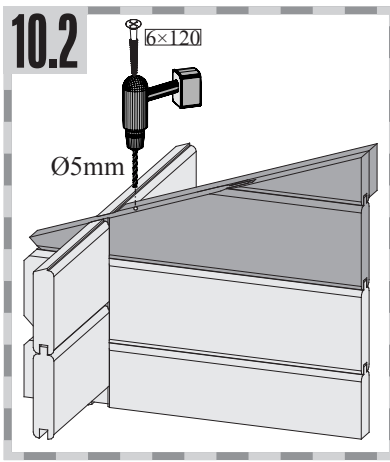
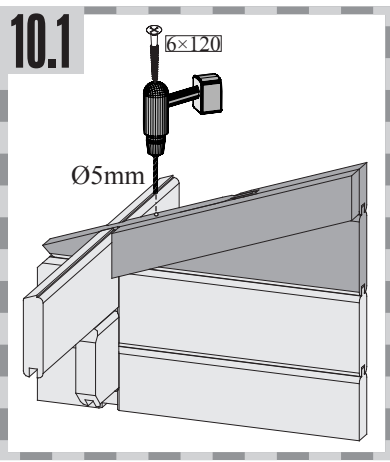
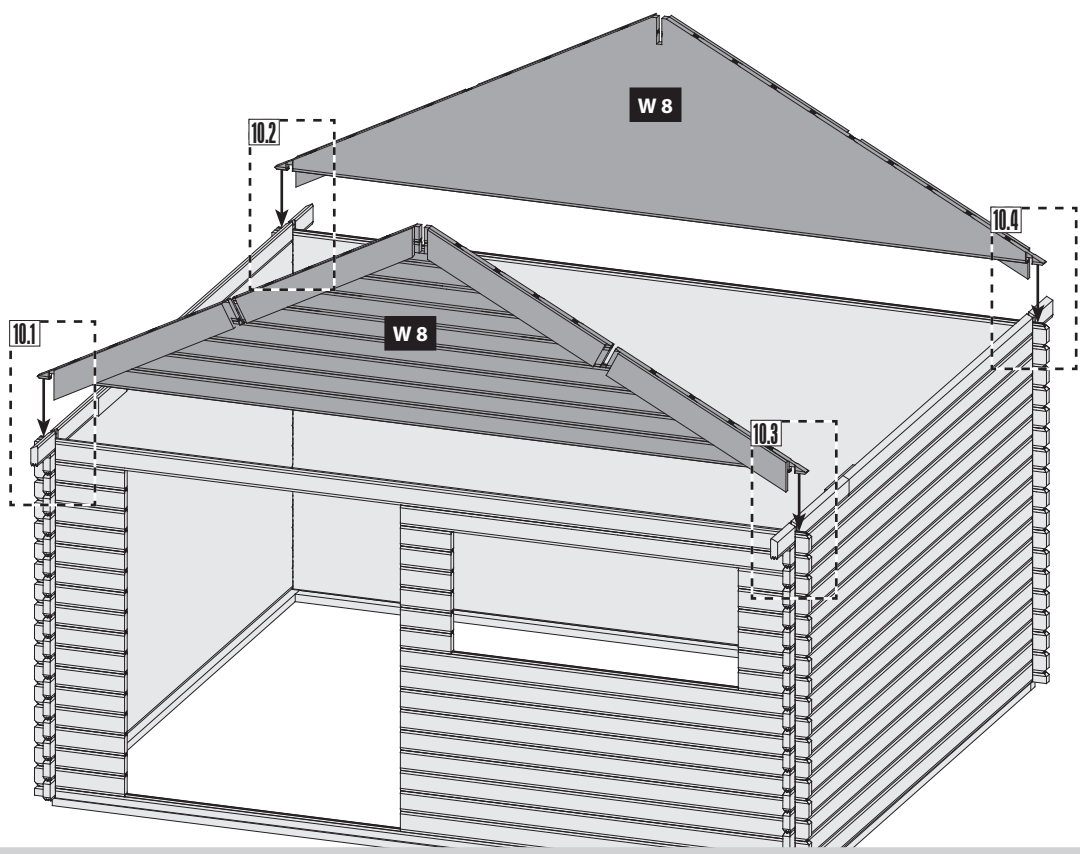



12 + 12.1 + 12.2

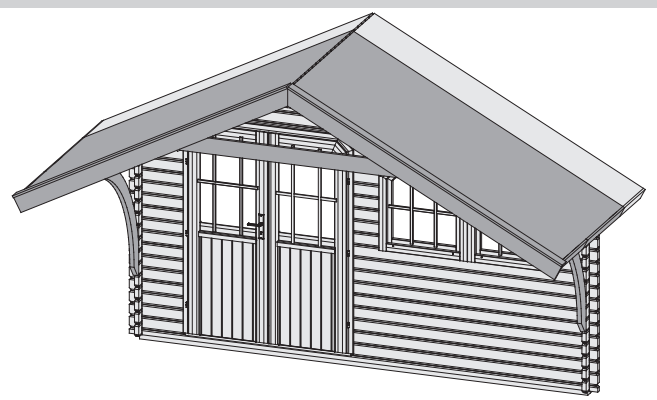

12 + 12.1 12.2

12

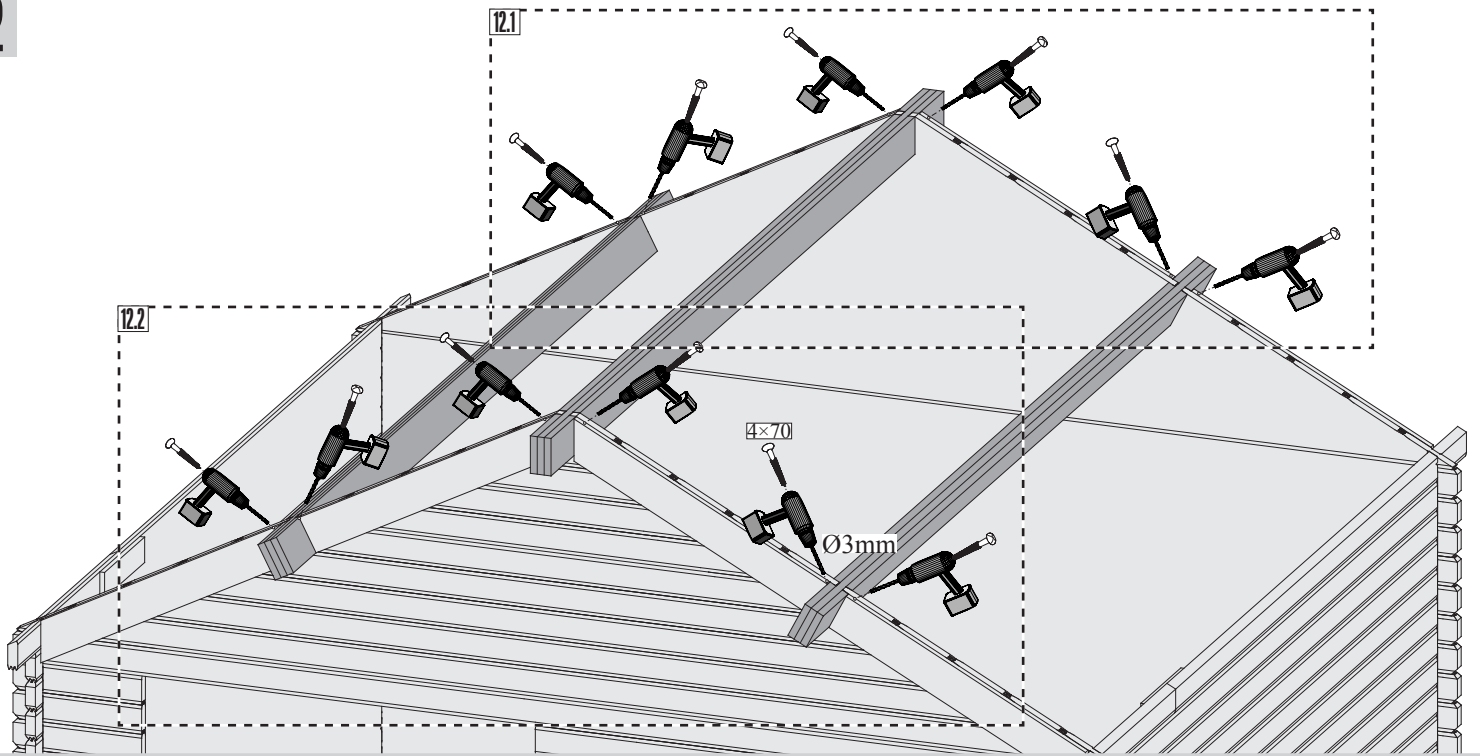



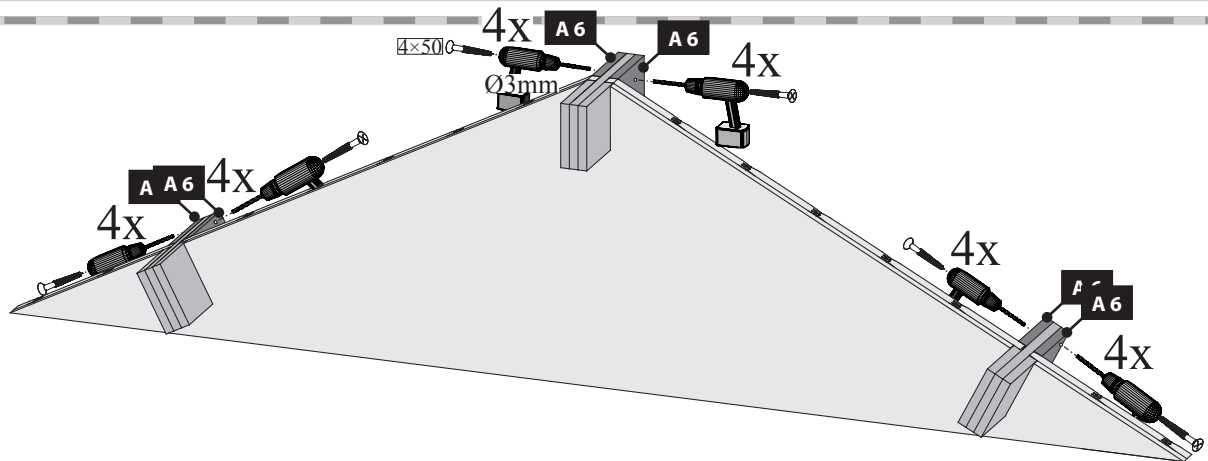

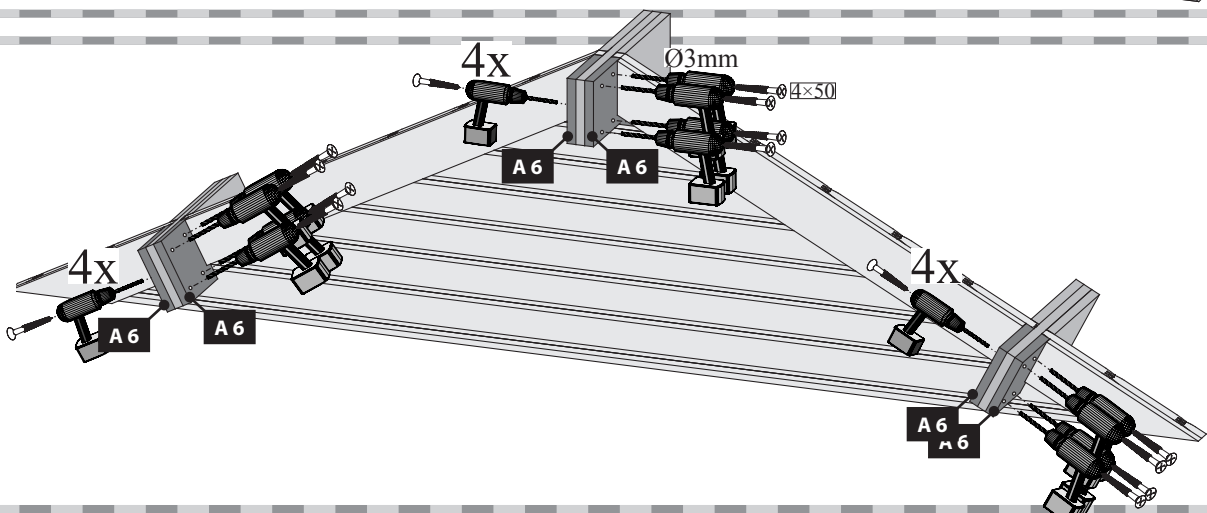

12.1

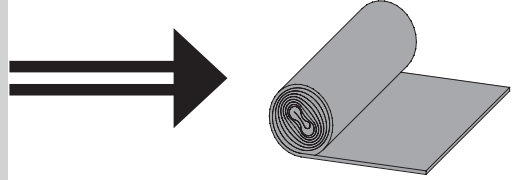
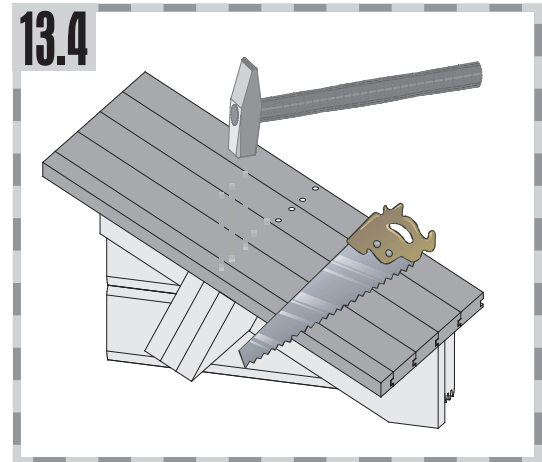
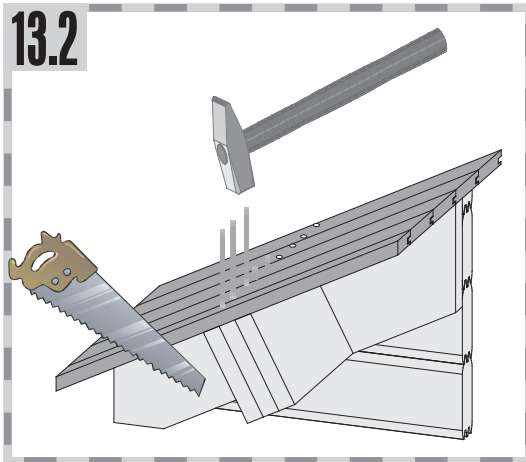
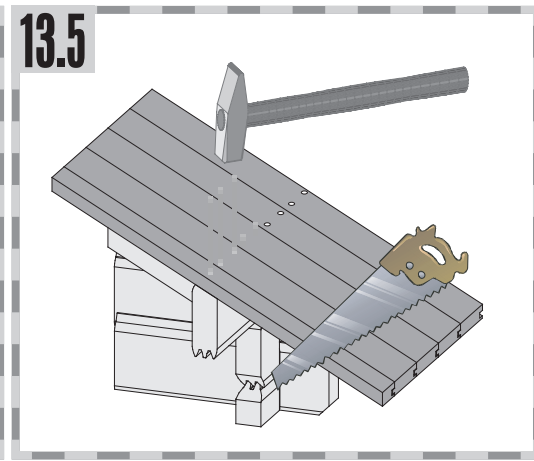
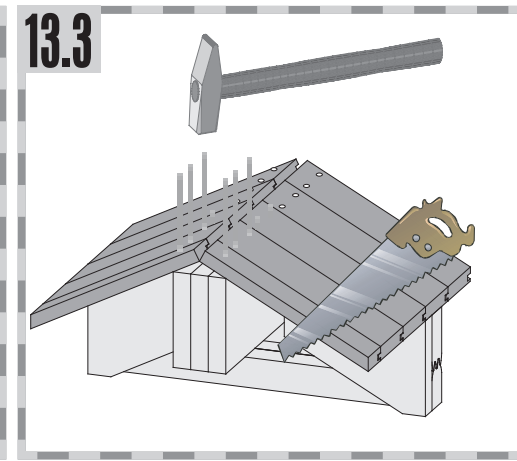
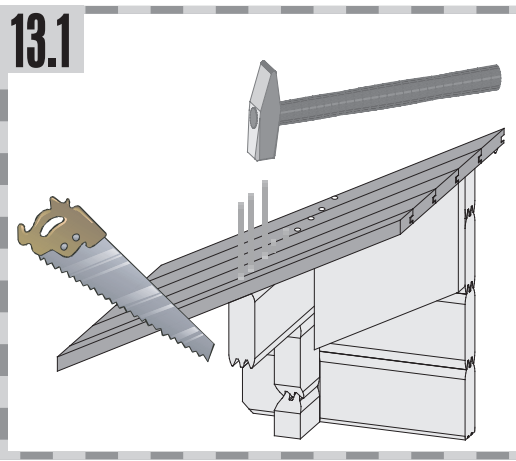
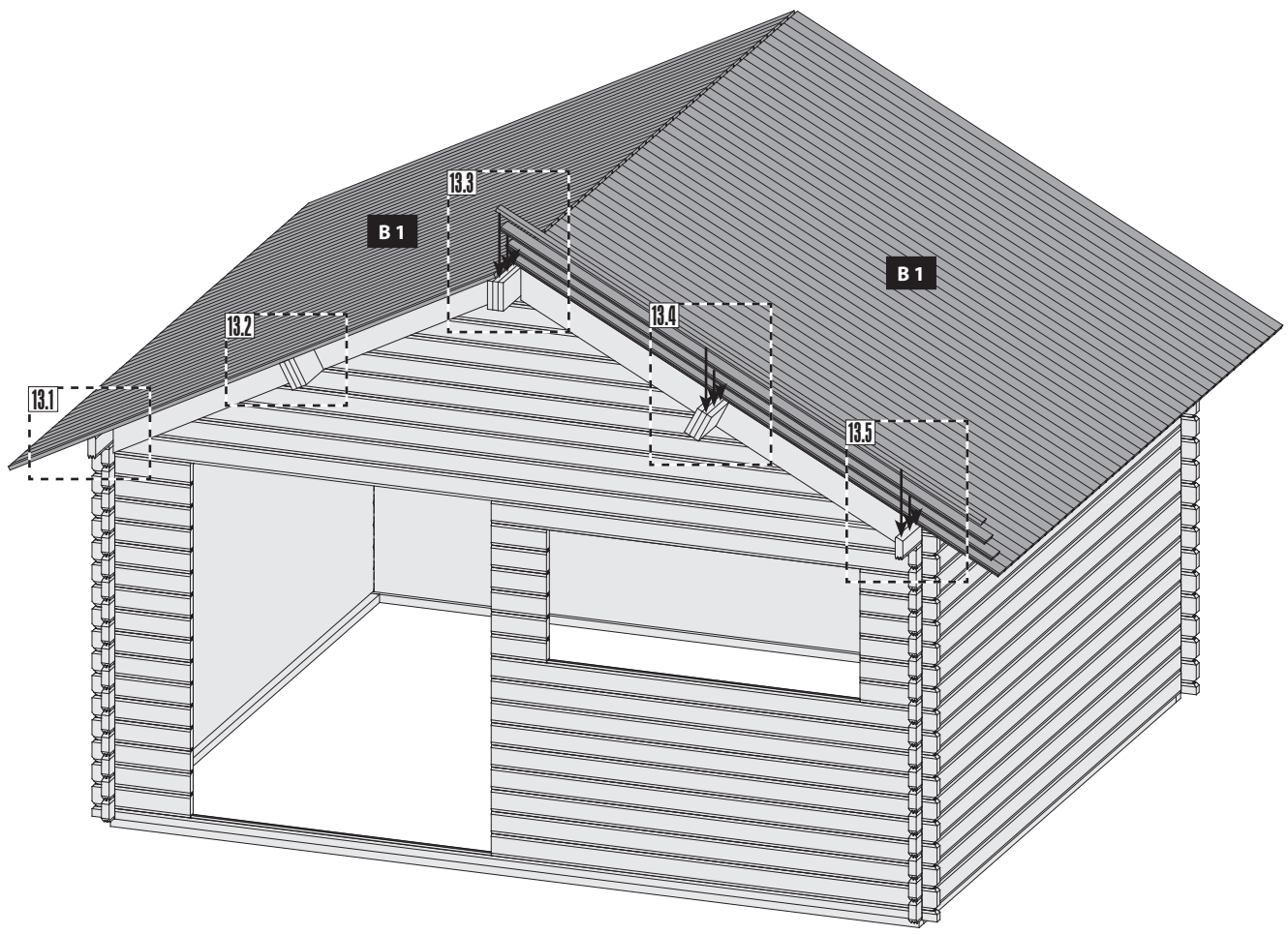

12.2





-  Die Eindeckung muss spätestens nach 2 Monaten durch ein geeignetes Produkt ersetzt werden
-  Le remplacement doit être au plus tard deux mois remplacés par un produit adapté
-  The replacement must be no later than 2 months replaced with a suitable product
-  De vervanging mag niet later dan 2 maanden vervangen door een geschikt product
-  El reemplazo debe ser a más tardar 2 meses reemplazados con un producto adecuado
-  La sostituzione deve essere entro e non oltre due mesi sostituiti con un prodotto adatto

 **Achtung, dies ist nur ein Verlegebeispiel.** Die Anzahl der Dachpappbahnen richtet sich nach Ihrer Hausgröße. Stöße von Dachpappe während einer Bahn sind mit einem Überschlag von 10cm der Dachpappe durchzuführen. Bei Verwendung von nur 4 Bahnen keine Firstbahn verwenden, seitliche Bahnen mit über den First legen.

Das Dach ist nicht begehbar. Die Konstruktion ist für eine Gesamtbelastung (Schnee, Wind) und nicht für eine Punktbelastung ausgelegt. Zur Montage empfehlen wir eine bauseitige Abstützung des Daches von unten.

Wenn Sie ein **Haus mit Satteldach** haben, sollten Sie bei der Verwendung von Schindeln keine Voreindeckung mit Dachpappe vornehmen. Hier wird nur an beiden Traufseiten ein 20cm breiter Streifen Dachpappe mit Überstand verlegt (Bild 02.2 unten).

Bei **Häusern mit Tonnendach** verlegen Sie bitte Dachpappe unter die Schindeln. Damit Sie lange Freude an Ihrem Gartenhaus haben, sollten Sie diese Dacheindeckung nach 2 Monaten erneuern.

 **Attention, il s'agit uniquement d'un exemple de pose.** Le nombre de bandes de carton bitumé dépend de la taille de la maison. La jointure du carton bitumé sur une bande doit être réalisée avec une superposition de 10 cm. Si 4 bandes seulement sont utilisées, ne pas avoir recours à une bande de faite, appliquer les bandes latérales sur le faite.

Ne pas marcher sur le toit ! La construction peut supporter une charge répartie sur sa totalité (neige, vent), et non concentrée sur un point précis. Lors du montage, il vous est recommandé d'étayer le toit par en dessous.

Si votre maison possède **un toit en bâtière**, ne pas poser de couverture préalable en carton bitumé pour les couvertures en bardeaux. Pour les **maisons avec toit en berceau**, poser du carton bitumé sous les bardeaux. Pour profiter le plus longtemps possible de votre maison de jardin, renouveler la couverture du toit tous les deux mois.

 **Note! This description is only an example.** The number of required rolls of roofing felt depends on the actual size of the summer house. When joining rolls of roofing felt end to end, the overlap must be 10 cm. When using just 4 rolls of roofing felt, always cover the horizontal ridge beam with the rolls from both sides.

The roof is not safe to walk on. The roof is designed for a total load (snow, wind) and not for a point load. We recommend you to always support the roof from below during installation.

When using shingles to cover a **house with a gable roof**, never use roofing felt as a preliminary covering. Always install the roofing felt underneath the shingles for **houses with an arched roof**. To ensure maximum enjoyment of your summer house, renew the roof covering after two month.

 **Let op, dit is slechts een montagevoorbeeld.** Het aantal dakviltbanen is afhankelijk van de grootte van uw huis. Voegen van dakvilt tijdens een baan dienen met een overlapping van 10cm uitgevoerd te worden. Bij gebruik van slechts vier banen geen firstbaan gebruiken, banen aan de zijkant ook over de first leggen.

Het dak is niet beloopbaar. De constructie is ontworpen voor een totaalbelasting (sneeuw, wind) en niet voor een puntbelasting. Voor de montage adviseren we te voorzien in een zelf aan te brengen steun voor het dak van onderen.

Wanneer u een **huis met zadeldak** hebt, zou u bij het gebruik van dakshingles geen voorafdekking met dakvilt moeten aanbrengen. Bij **huizen met een boogdek** dient u dakvilt onder de shingles aan te brengen. Om lang plezier van uw tuinhuisje te hebben, zou u deze dakafdekking na twee manden vervangen.

 **Cuidado, éste es sólo un ejemplo de instalación.** La cantidad de tiras de tela asfáltica depende del tamaño de su caseta. Las juntas de tela en una tira se realizan solapando la tela asfáltica 10 cm. Cuando sólo se empleen cuatro tiras no se debe utilizar ninguna tira de cumbrera, sino colocar las tiras laterales sobre la cumbrera.

El techo no es transitable. La construcción está preparada para cargas totales (nieve, viento) y no para cargas puntuales. Para el montaje se recomienda apuntalar el techo por debajo.

Si tiene una casa con **tejado a dos aguas**, en caso de utilizar cubierta de ripias no se debería cubrir previamente con tela asfáltica. En las casas **con tejado en forma de tonel**, por favor coloque la tela asfáltica debajo de la cubierta de ripias. Para disfrutar de su caseta de jardín durante mucho tiempo se aconseja renovar la cubierta del tejado cada 2 meses.

 **Attenzione, questo è solo un esempio di posa!** La quantità dei rulli di cartone catramato dipende dalle dimensioni della casa. Le congiunzioni del cartone catramato in una corsia vanno con una sovrapposizione di 10 cm dei due pezzi di cartone catramato. Se si impiegano 4 file non disporre una sul colma ma far passare un bordo oltre il colmo stesso.

Non salire sul tetto. La costruzione è progettata per un carico diffuso (neve, vento) e non per una concentrazione puntuale del peso. Per il montaggio si consiglia un supporto del tetto con una costruzione posta sotto di esso.

Se si utilizza la **scandola per rivestire il tetto**, non si dovrebbe utilizzare il rivestimento in cartone catramato. Per **case con tetto a botte**, posare il cartone catramato sotto la scandola. Per garantire una lunga durata della casetta da giardino, è necessario rinnovare la copertura del tetto ogni 2 mesi.

01

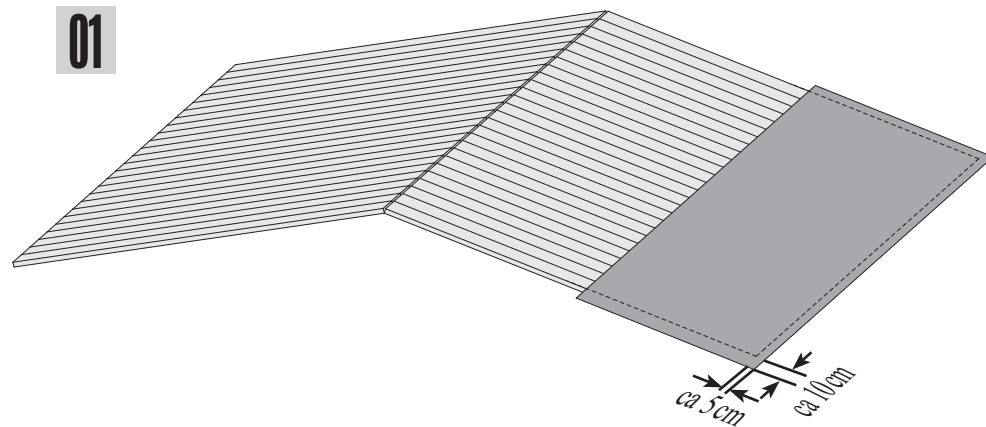

02

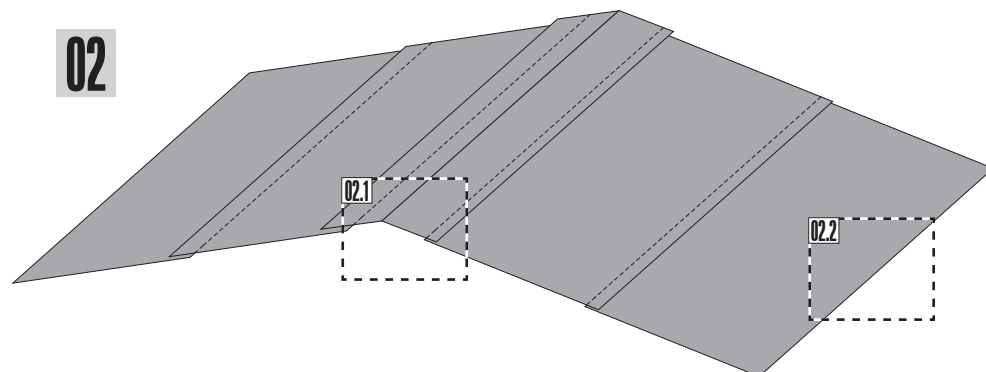

02.1

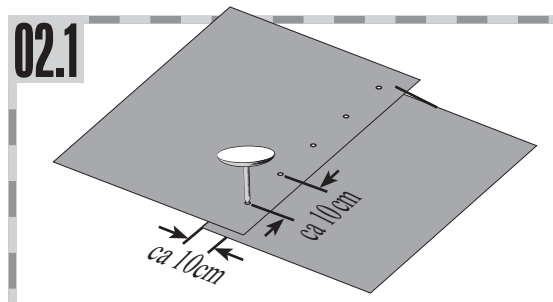

02.2

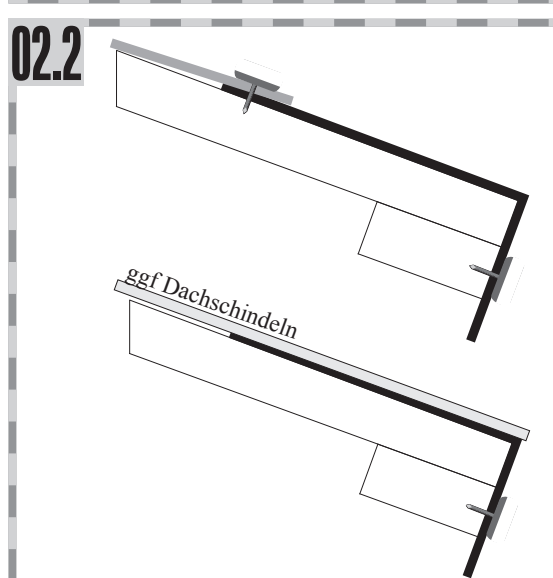

15 2x

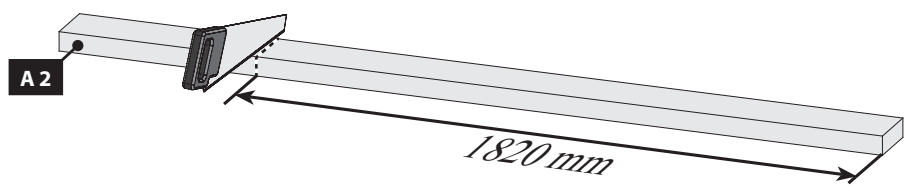

16

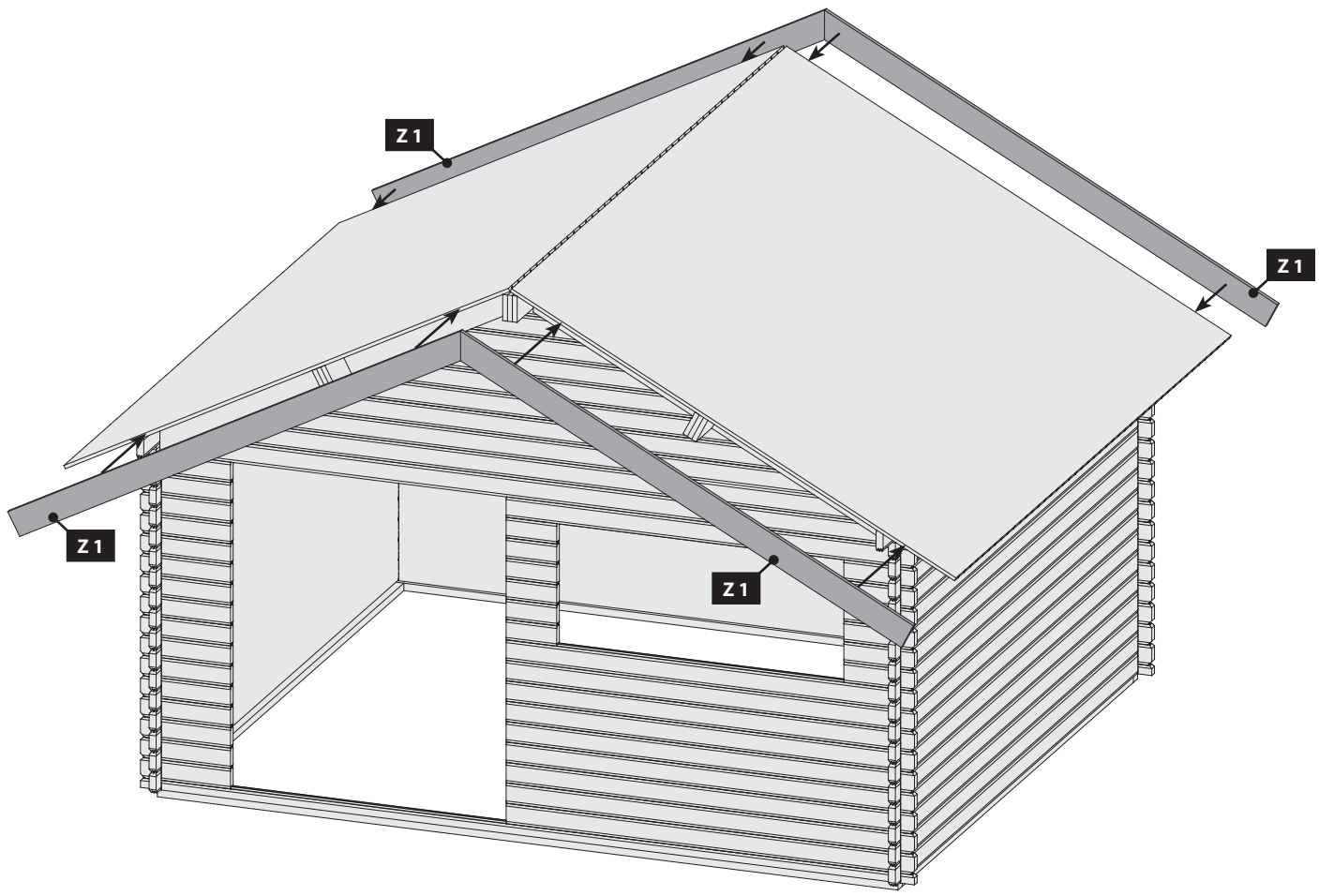

17

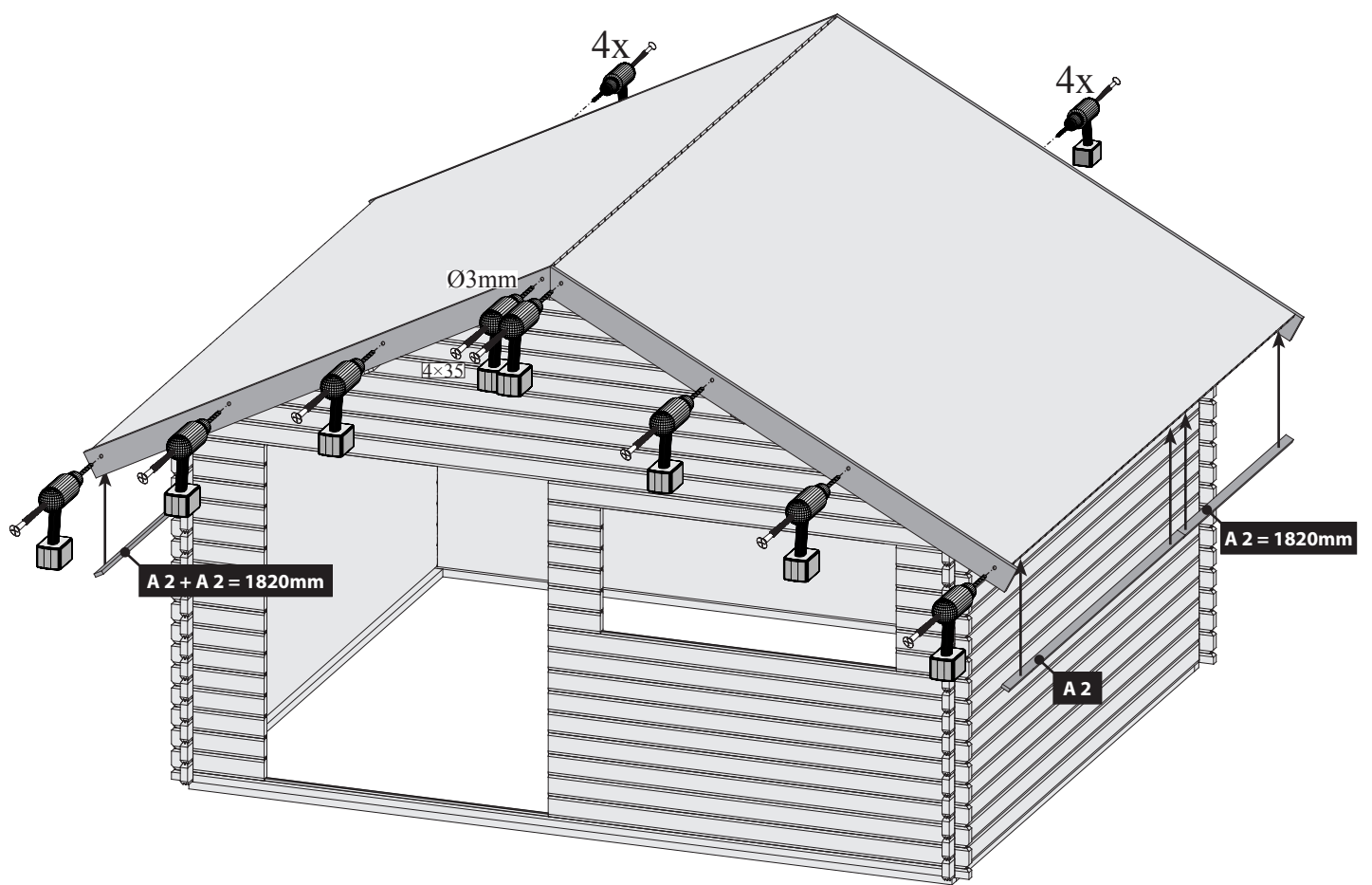

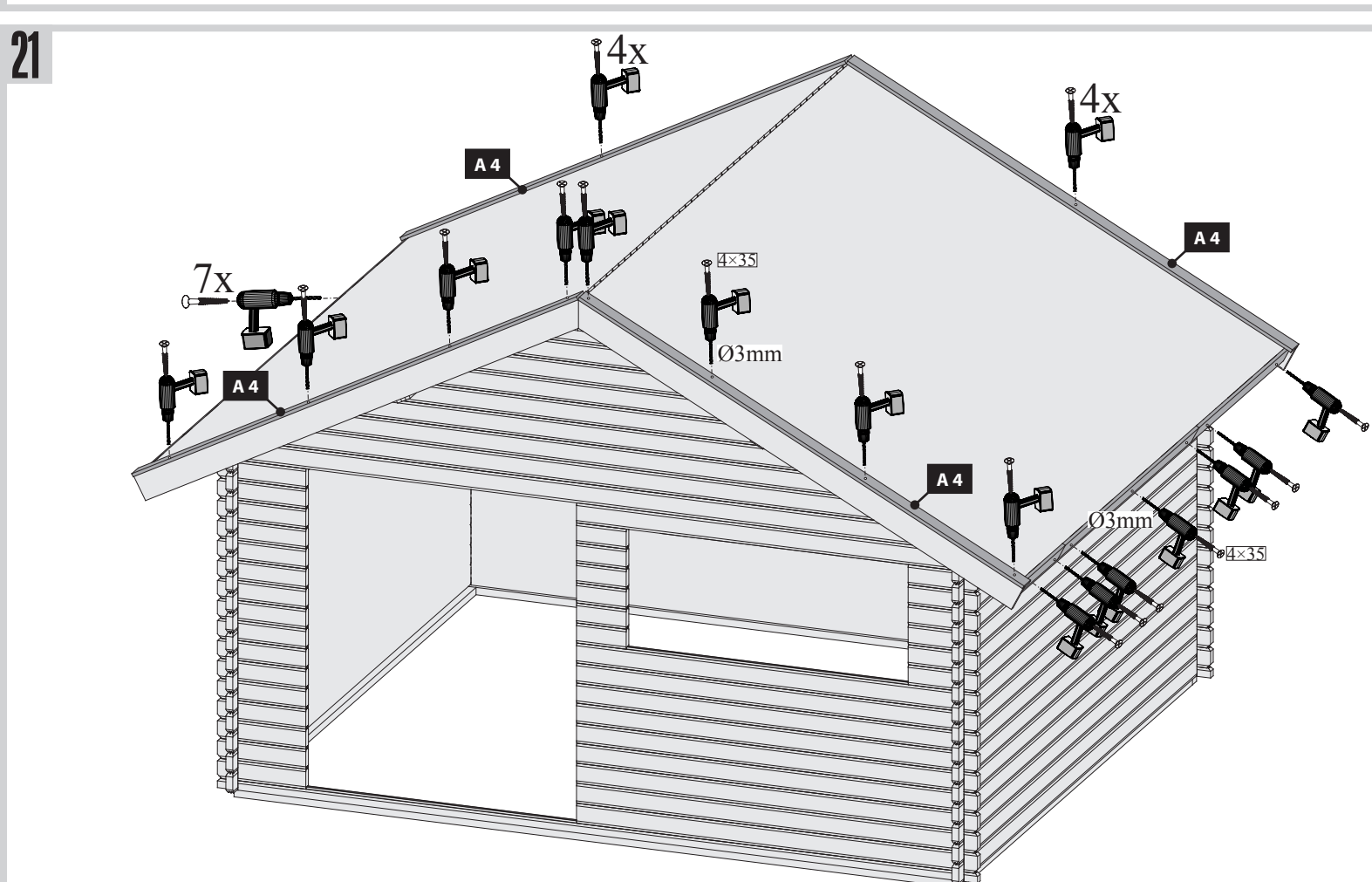
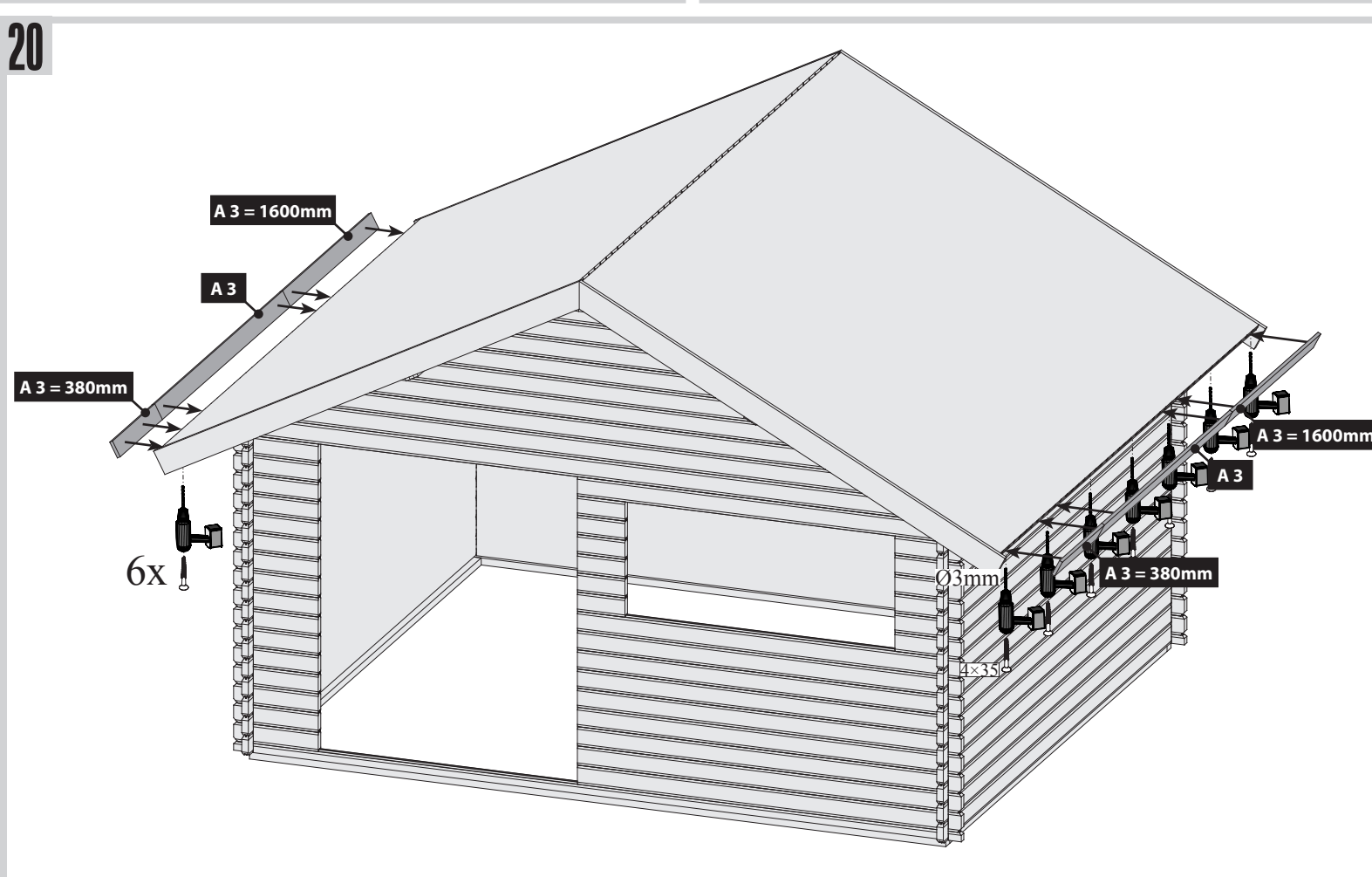
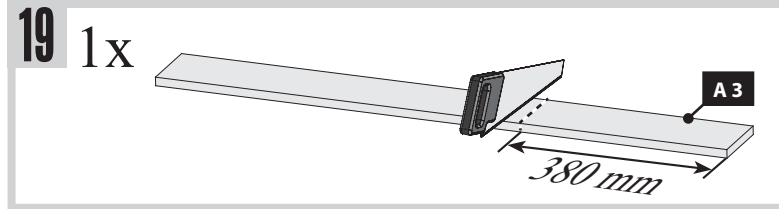
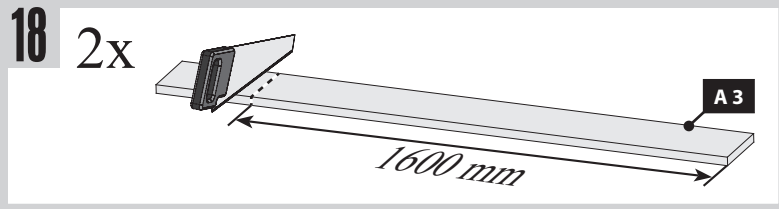

22

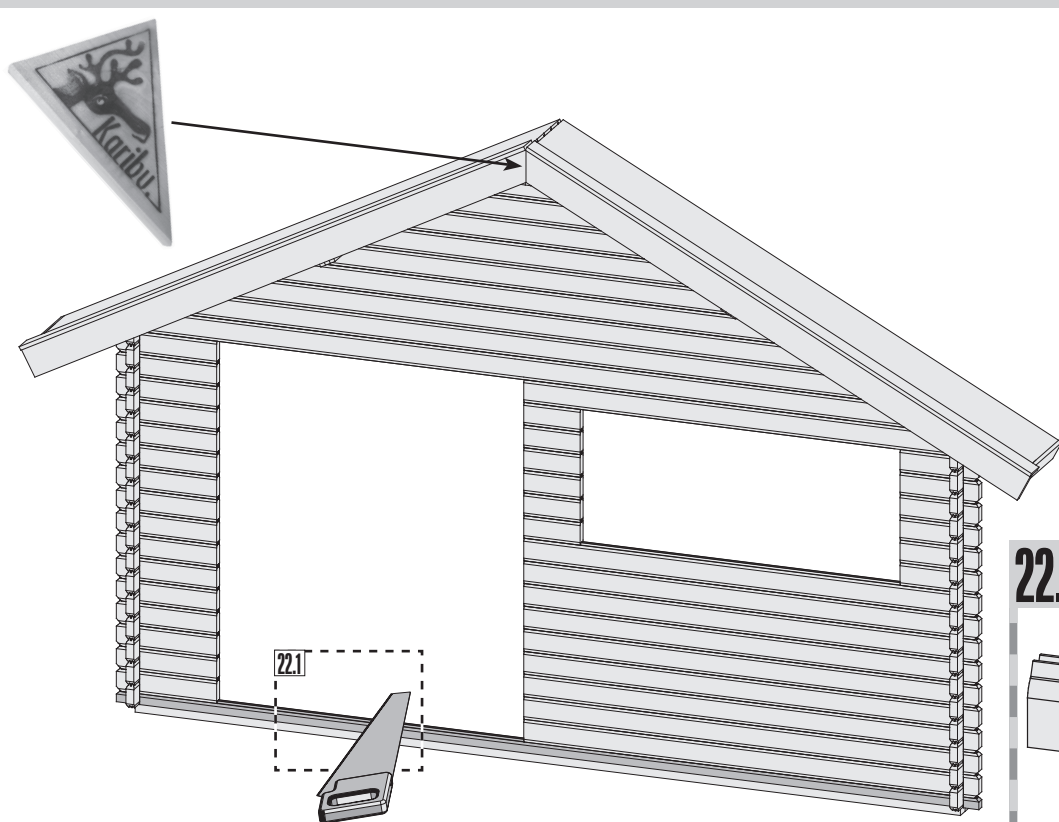

23

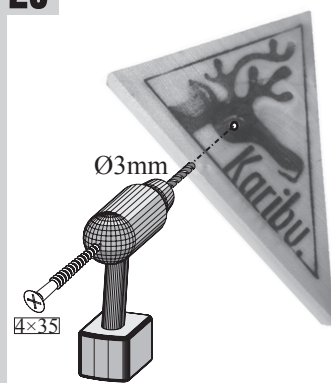

22.1

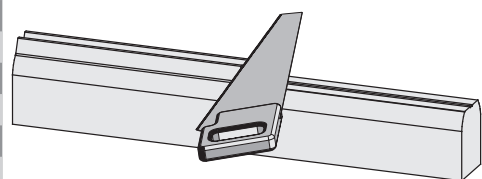

24

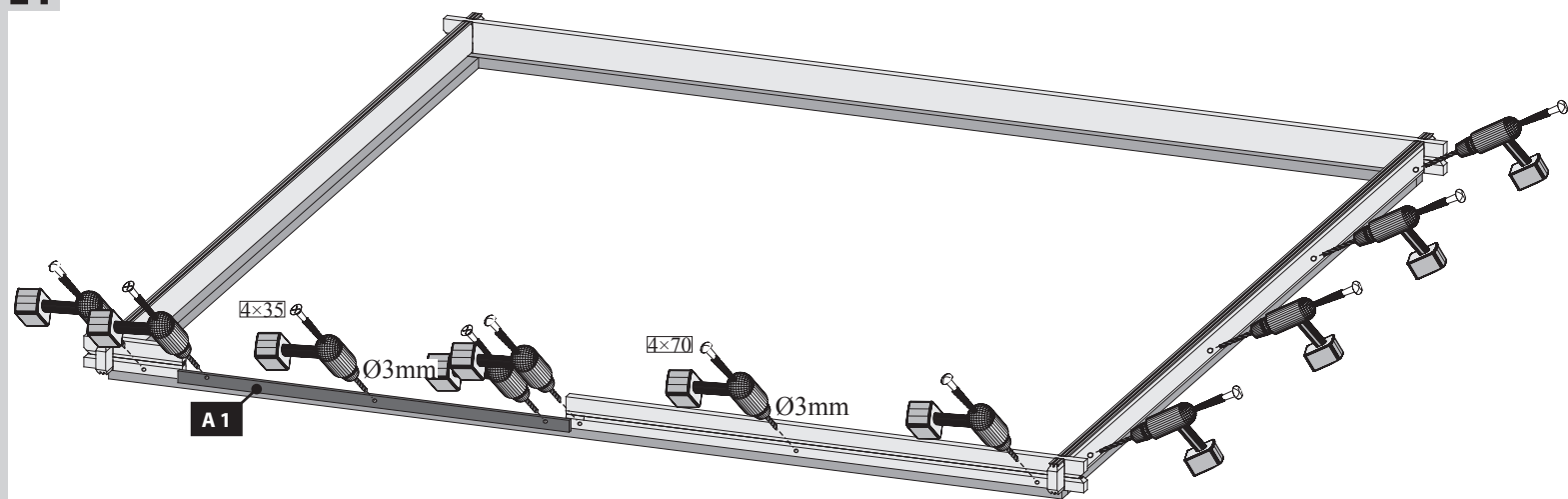

25

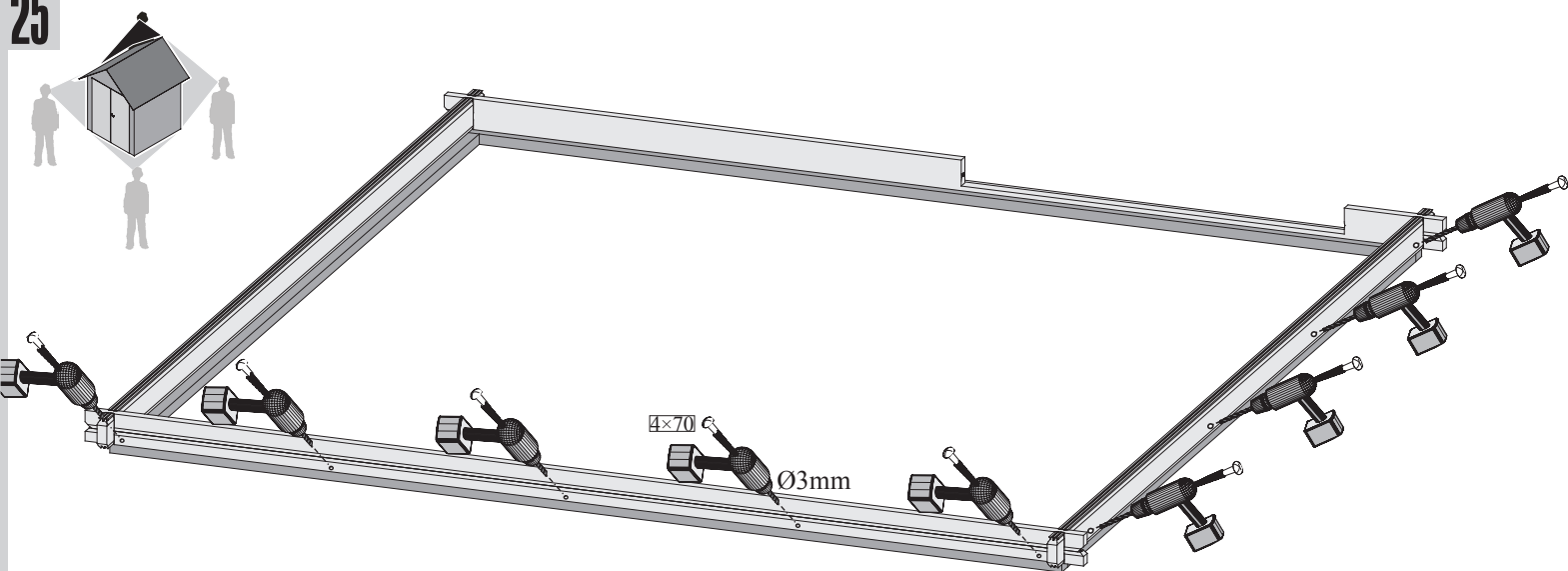

# 55341 55343

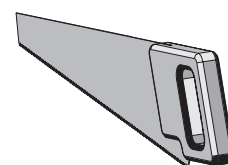
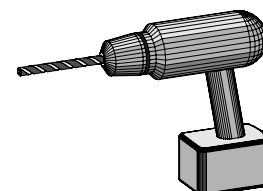
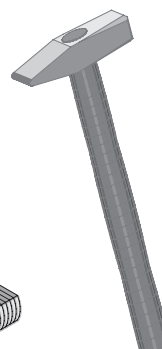
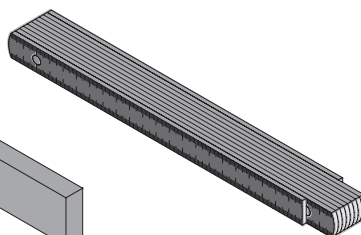
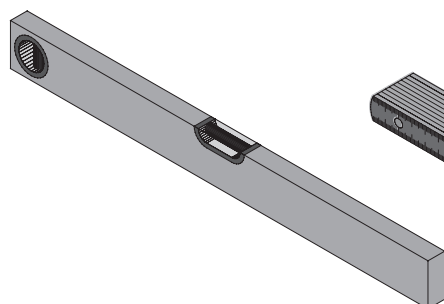
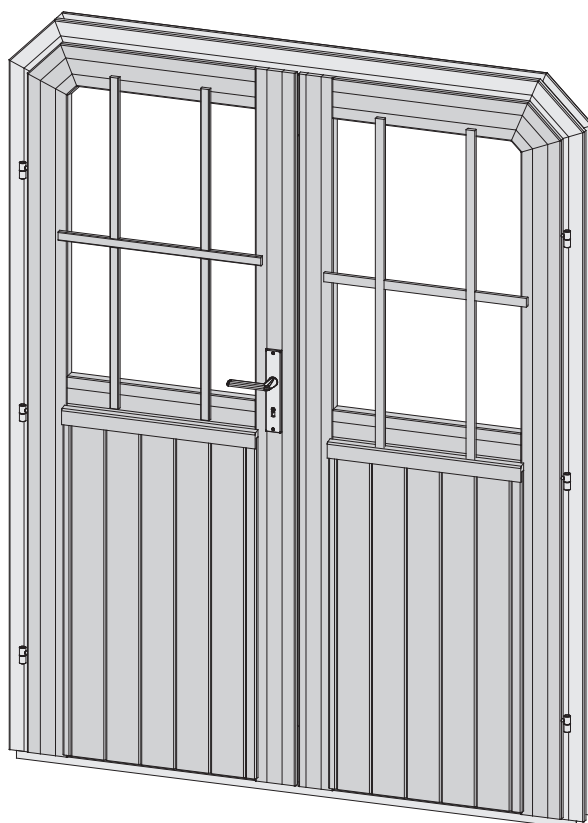

 **Türmontage**

 **Assemblage de porte**

 **Door assembly**

 **Assemblage van de deur**

 **Montaje de la puerta**

 **Assemblea del portello**

 **Service-Hotline: +49 421 38693 33**



Vergleichen Sie zuerst die Materialliste mit Ihrem Paketinhalt! Bitte haben Sie Verständnis, dass Beanstandungen nur im nicht aufgebauten Zustand bearbeitet werden können!



Commencez par comparer la liste du matériel avec le contenu de votre paquet! Sachez que nous traitons uniquement les réclamations concernant le matériel à l'état non monté!



First compare the list of materials with your package contents! Please understand that complaints can be processed in the non-built status only!



Vergelijk eerst de lijst van materialen met de inhoud van uw pakket! Reclamaties kunnen alleen in behandeling worden genomen zolang de onderdelen nog niet zijn gemonteerd!



En primer lugar, compare la lista de material con el contenido del paquete. Rogamos entienda que las reclamaciones sólo pueden ser tramitadas antes de montar el objeto!



Confrontate questa distinta materiali prima con il contenuto del pacchetto! Vi preghiamo di comprendere che eventuali reclami possono essere accolti solo prima del montaggio!

## 55341 55343

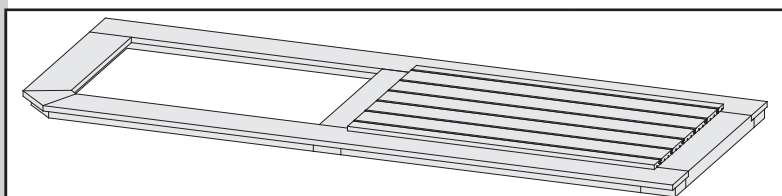

1 x DFT1

ID 39641

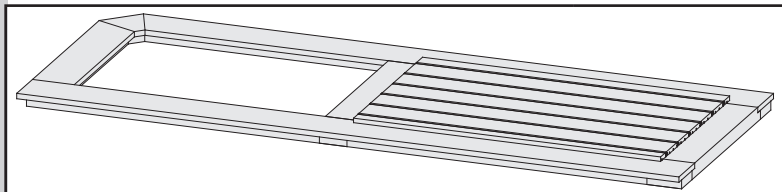

1 x DFT2

ID 39643

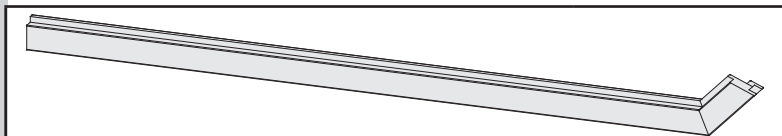

2 x DFT3

ID 39647-1

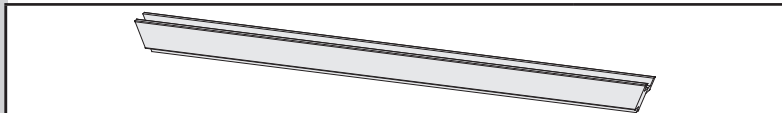

1 x DFT4

ID 39647-2

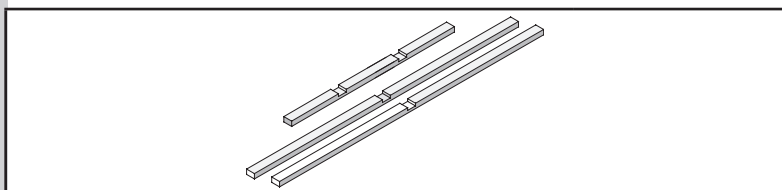

2 x DFT5

ID 39645

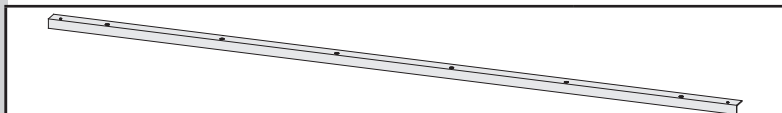

1 x DFT6

ID 39658

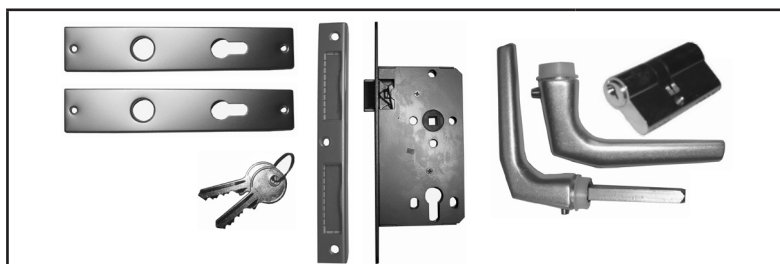

1 x

ID 15979

01

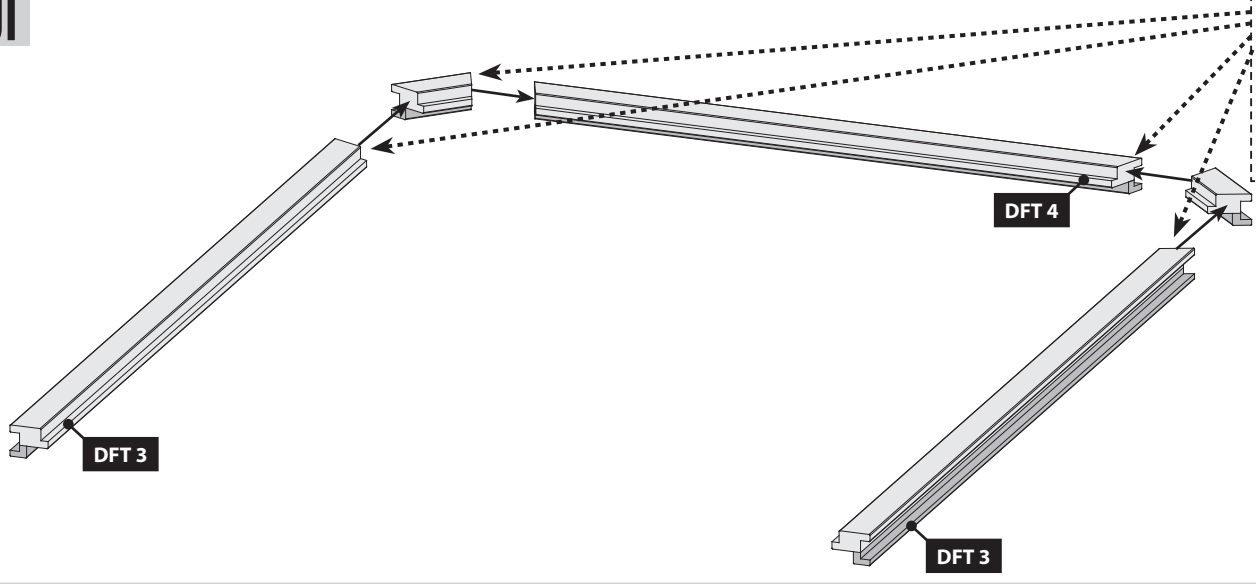

- Leim
- Coller
- Glue
- Lijm
- Pegamento
- Colla



02

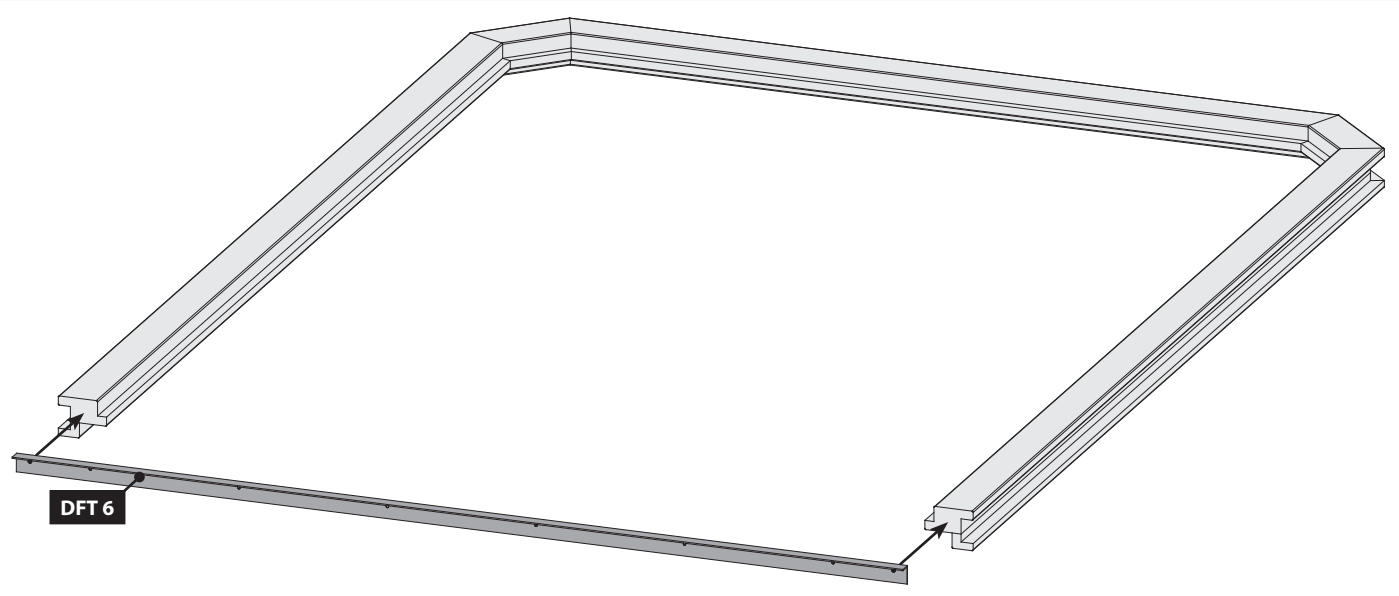

03

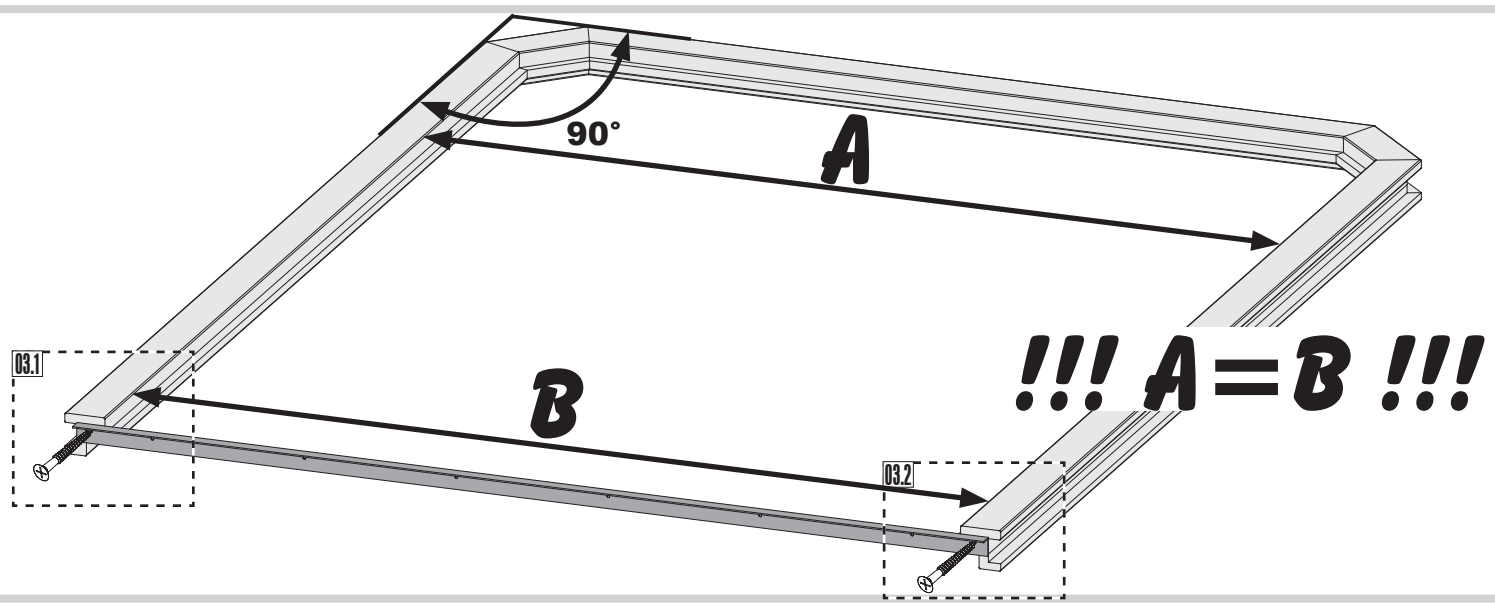

03.1

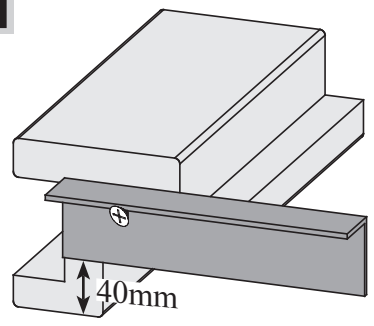

03.2

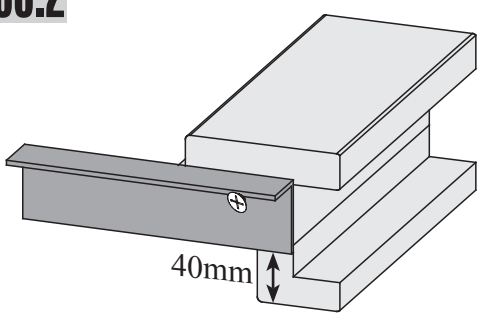

04

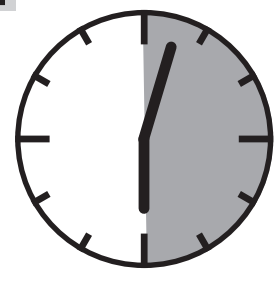

6h

05

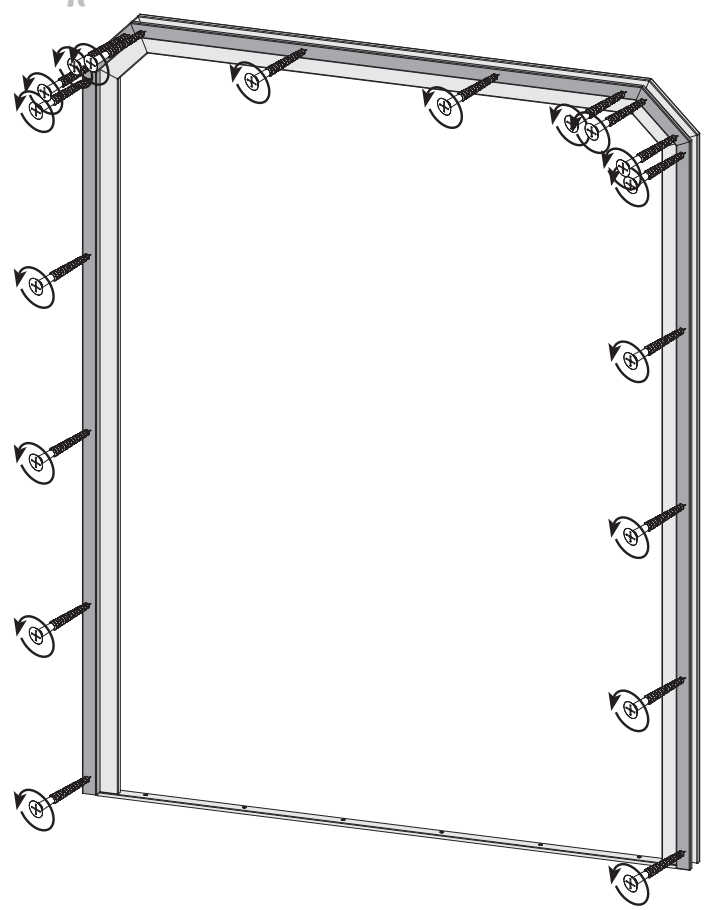
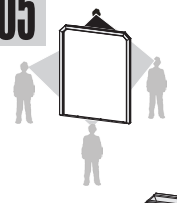

06

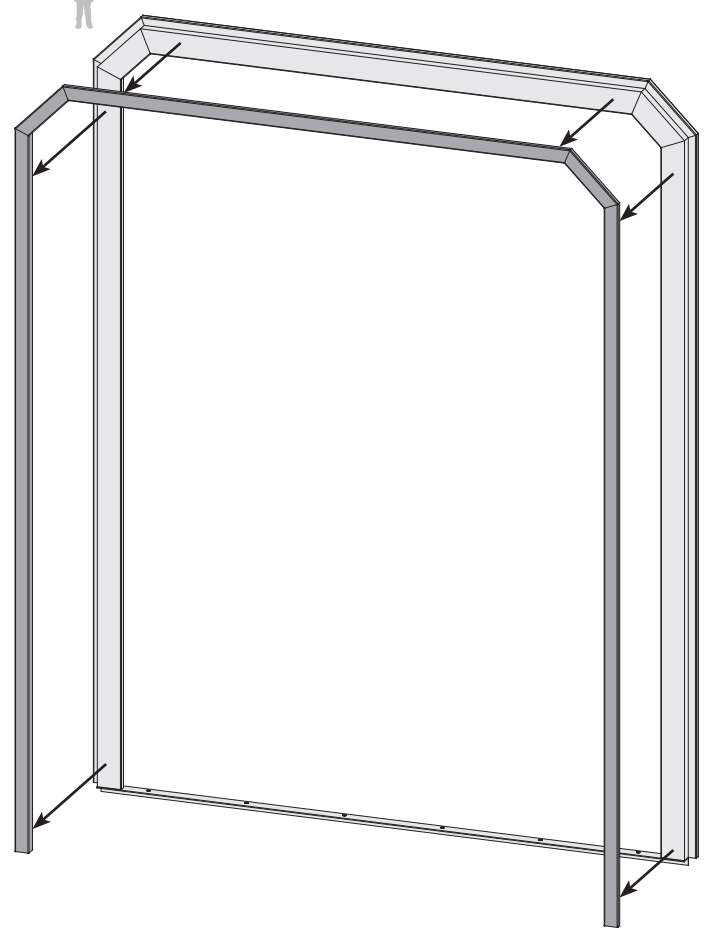
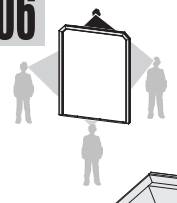

07

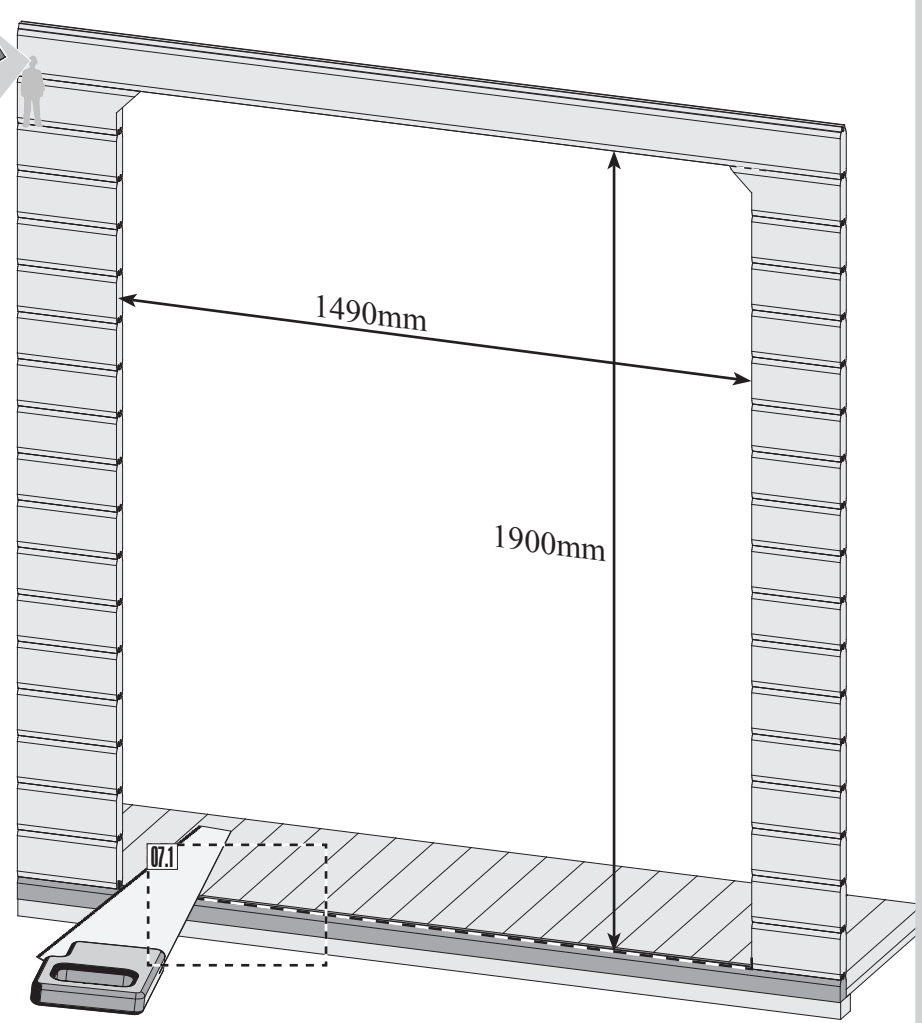
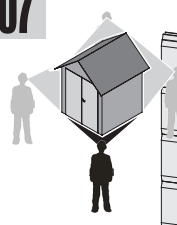

07.1

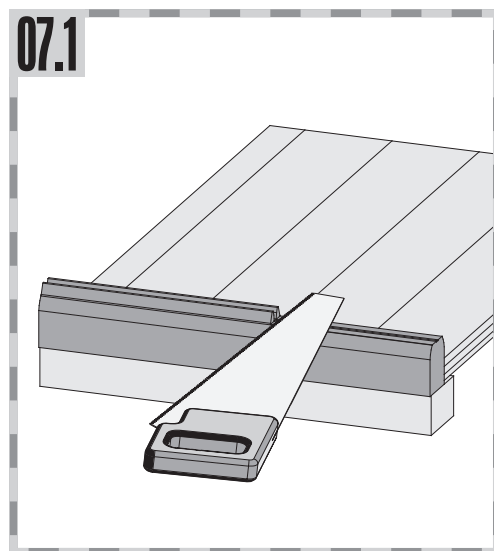

08

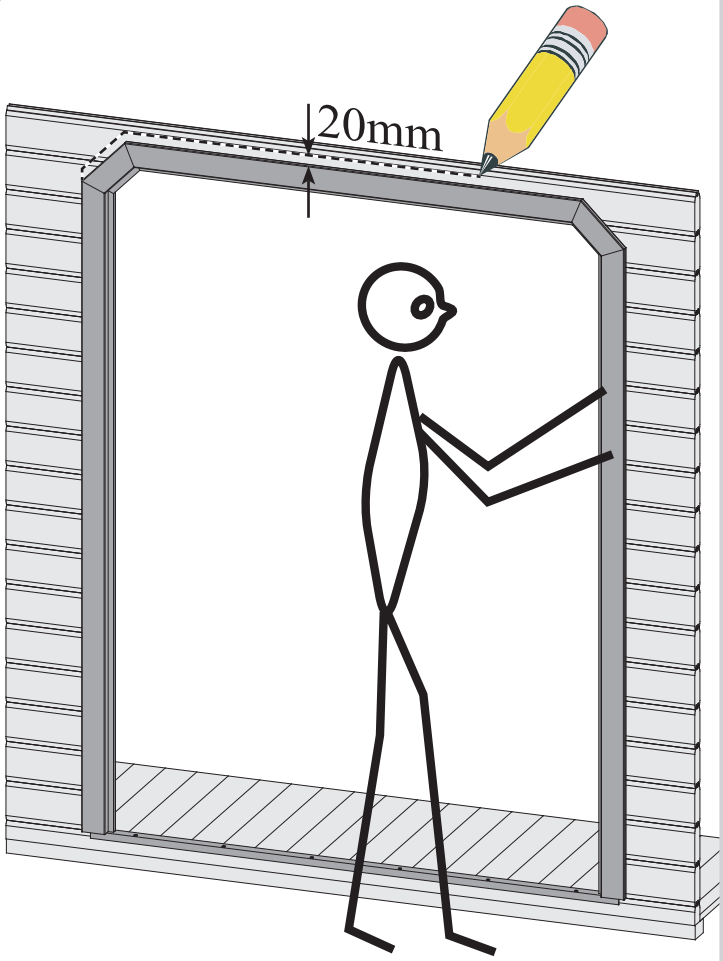

09

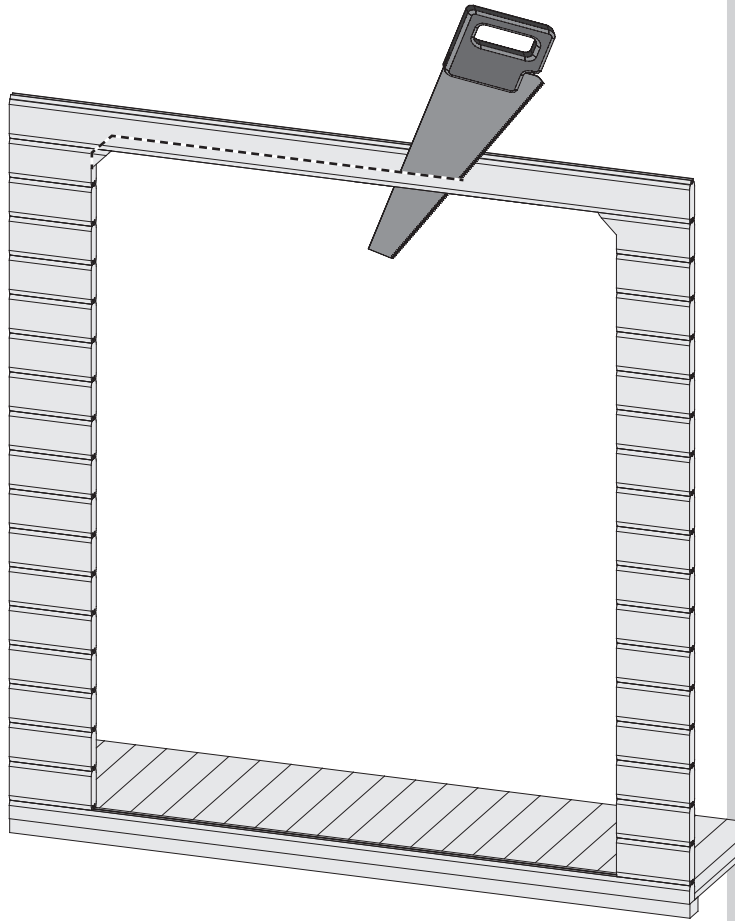

10

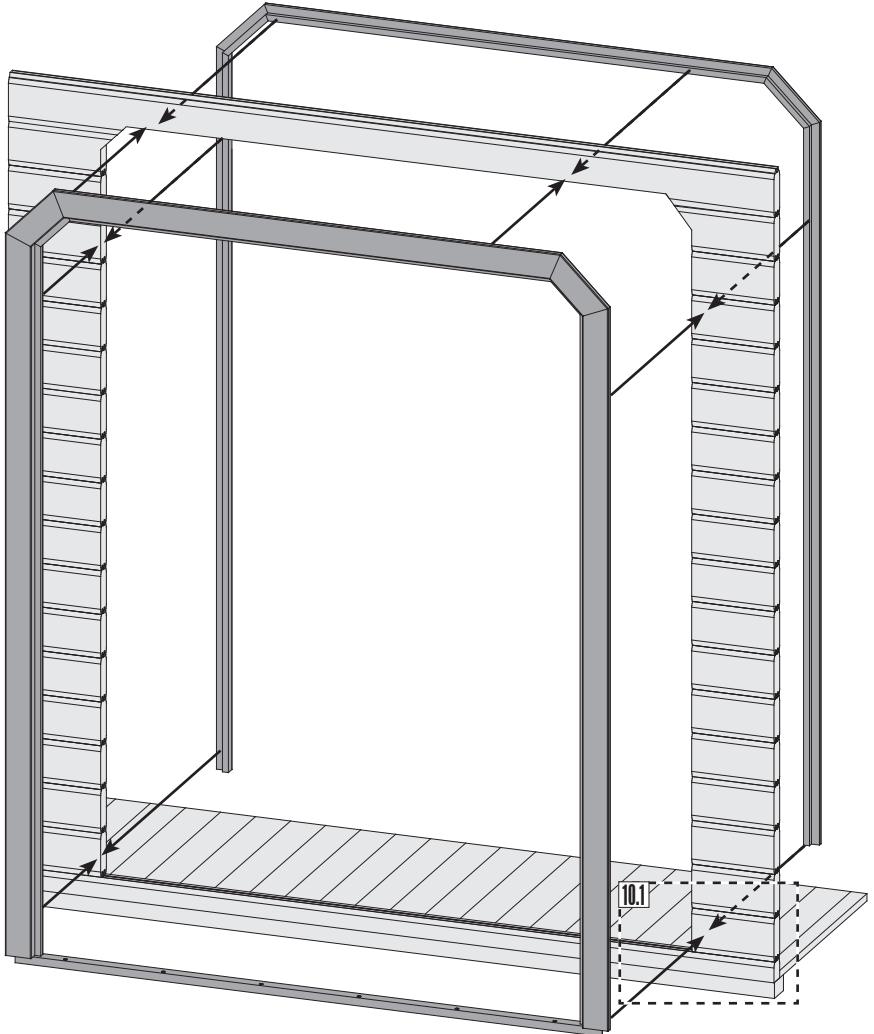

10.1

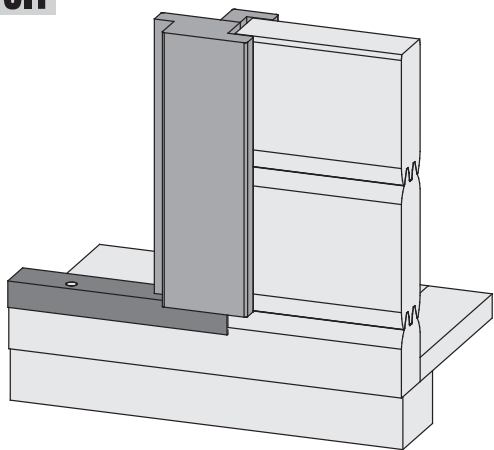

11

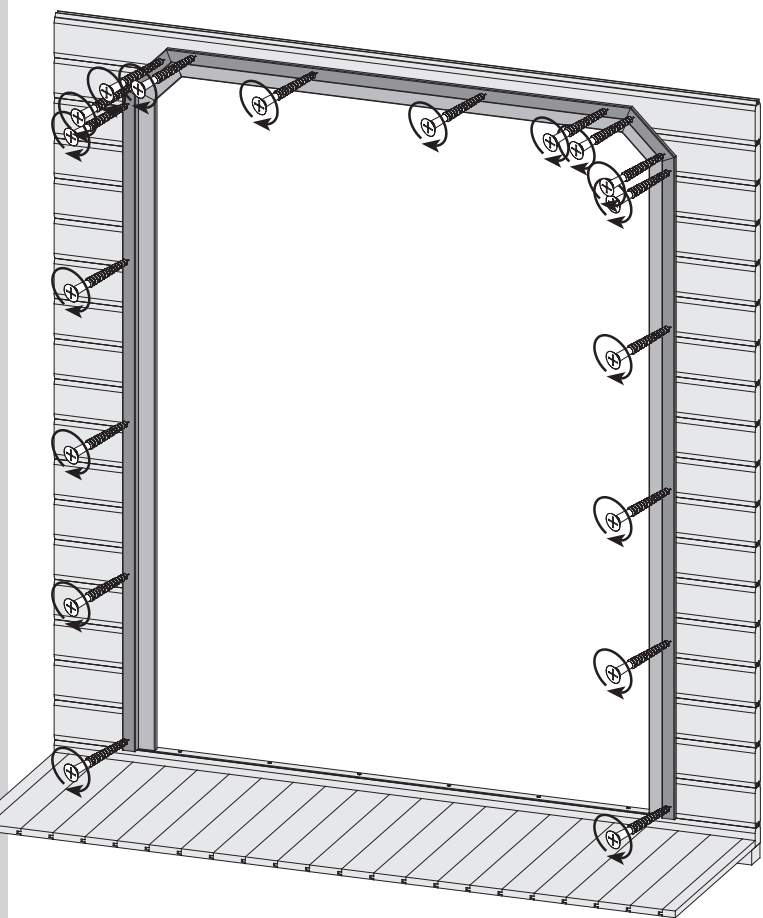
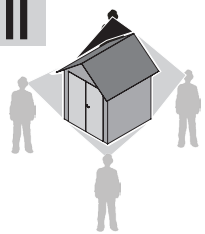

12

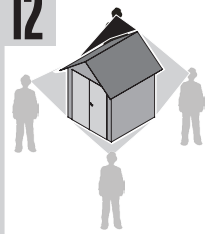

Die Hütchenprofile dürfen **nur mit der Tür** und nicht mit dem Haus verschraubt werden! De afdekprofielen mogen **uitsluitend op het deur**, niet op het huisje worden vastgeschroefd! Les profils de panne sont à visser à **la porte**, non à la maison! Screw the capping profiles **onto the door only**, not onto the cabin! Los perfiles de sombrerete **sólo se pueden atornillar a la puerta**, no a la caseta! I cappellotti possono essere avvitati **solo al portello**, non alla casa!

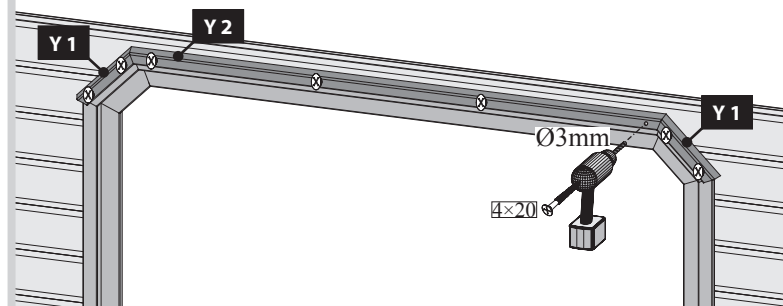

13

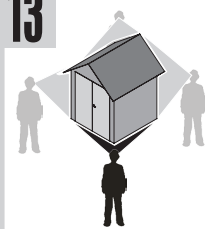

Die Hütchenprofile dürfen **nur mit der Tür** und nicht mit dem Haus verschraubt werden! De afdekprofielen mogen **uitsluitend op het deur**, niet op het huisje worden vastgeschroefd! Les profils de panne sont à visser à **la porte**, non à la maison! Screw the capping profiles **onto the door only**, not onto the cabin! Los perfiles de sombrerete **sólo se pueden atornillar a la puerta**, no a la caseta! I cappellotti possono essere avvitati **solo al portello**, non alla casa!

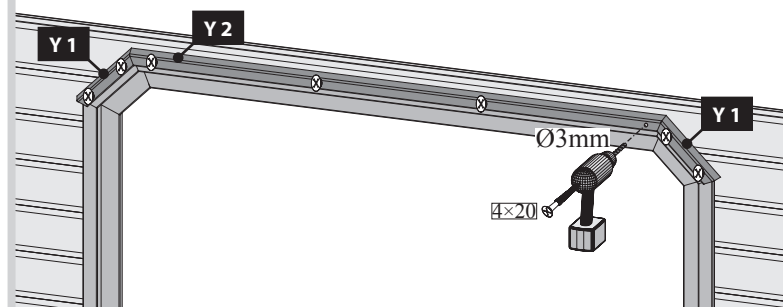

14 2x

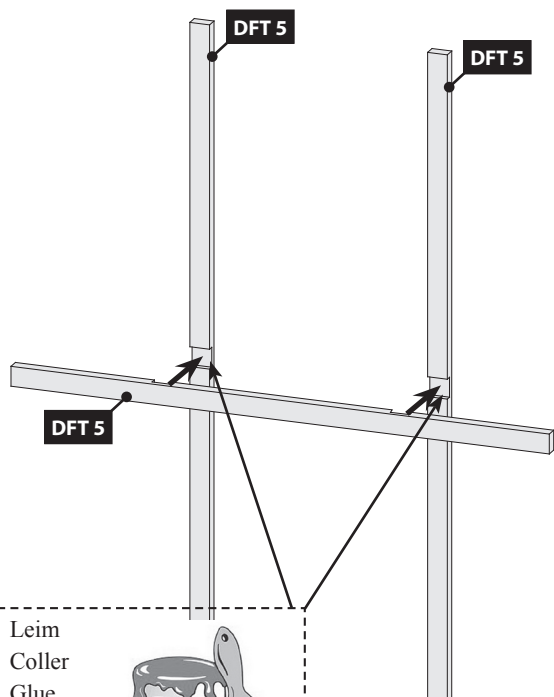

Leim  
Coller  
Glue  
Lijm  
Pegamento  
Colla



15

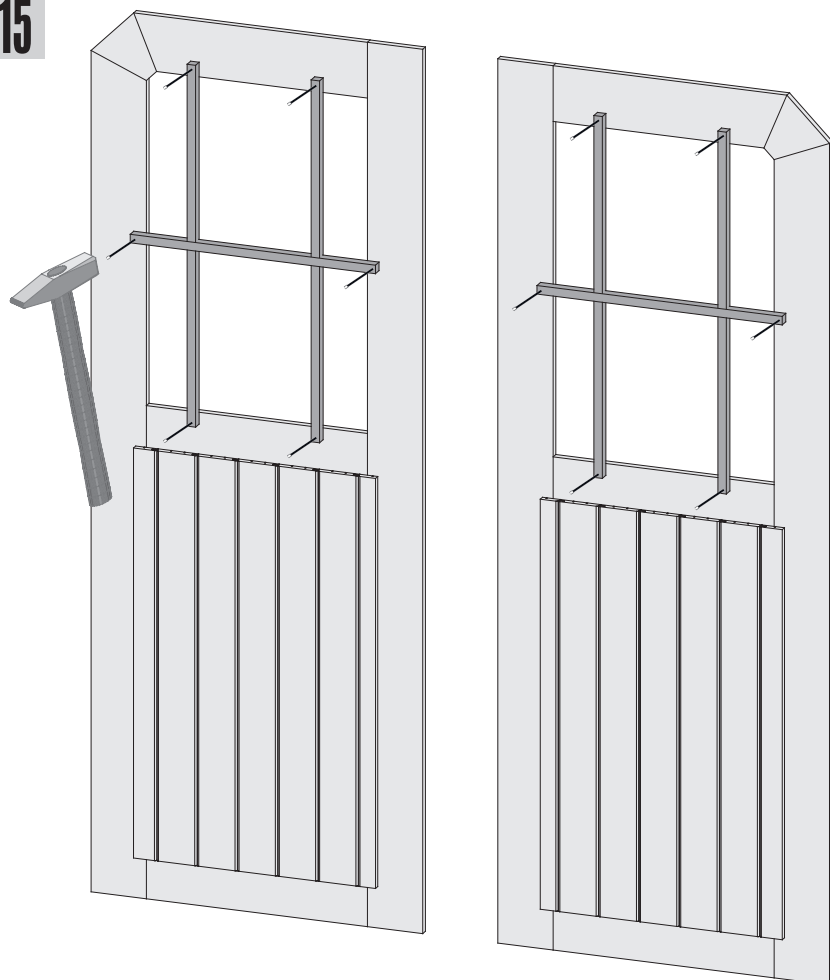

16

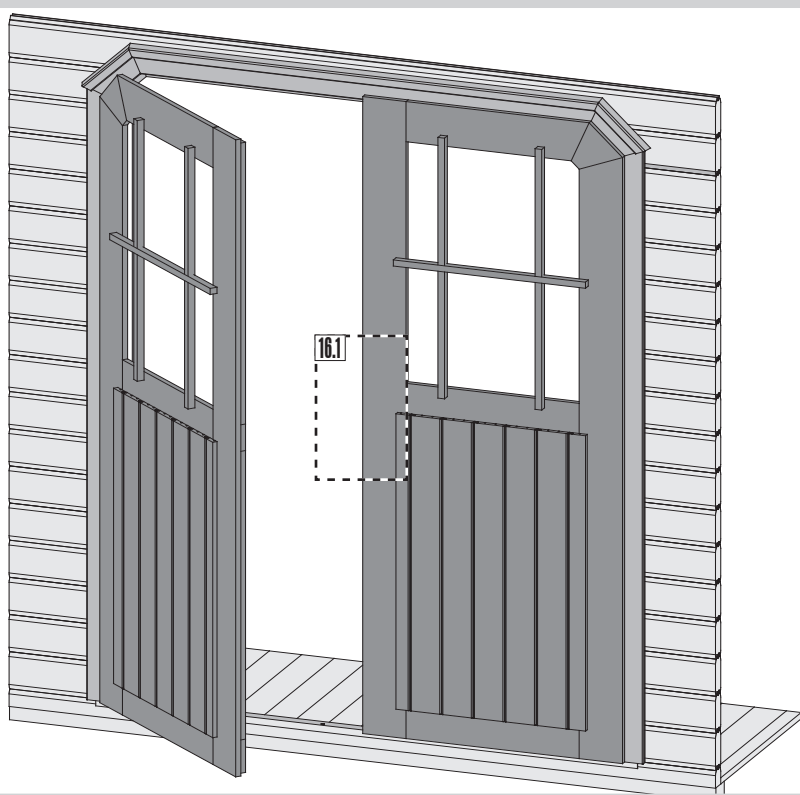

16.1-1

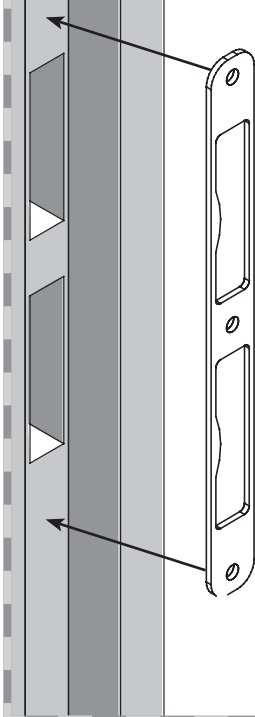

16.1-2

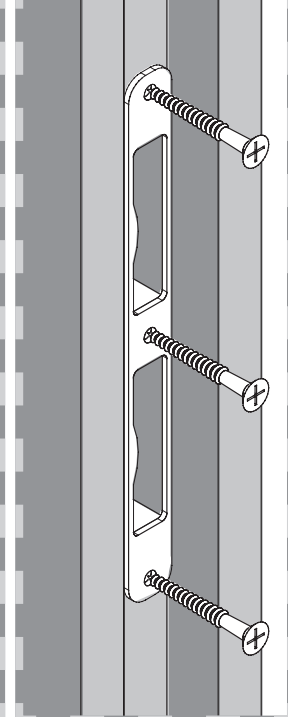

16.1-3

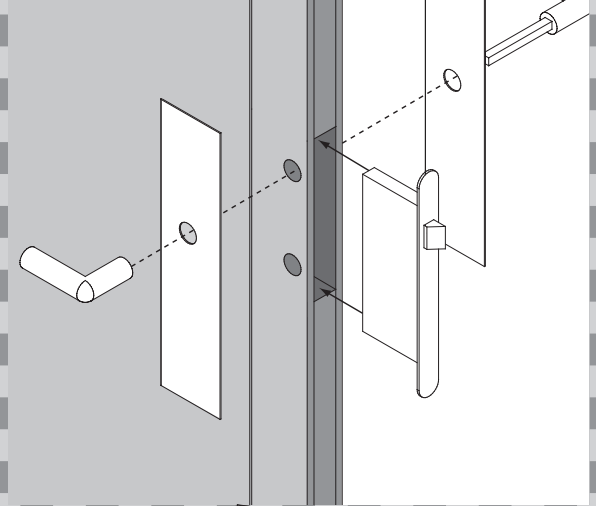

16.1-4

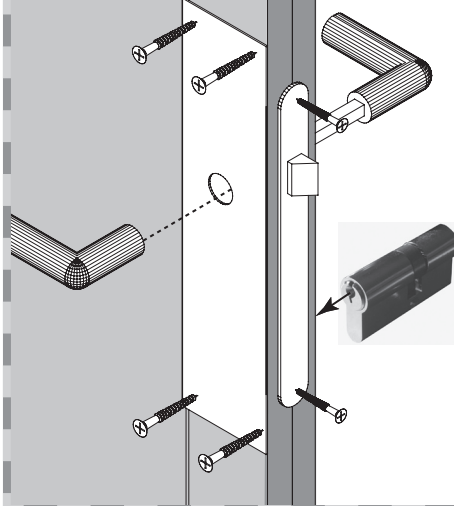

16.1-5

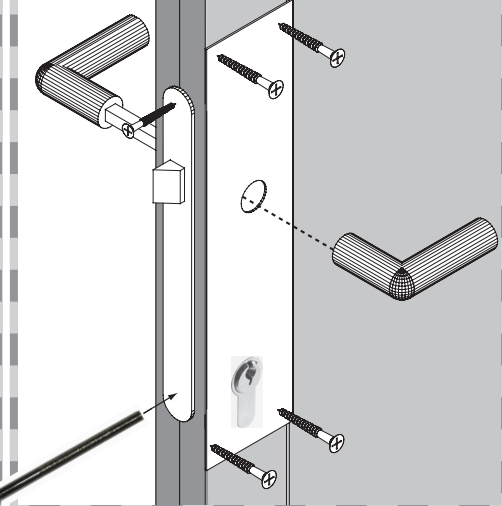

17

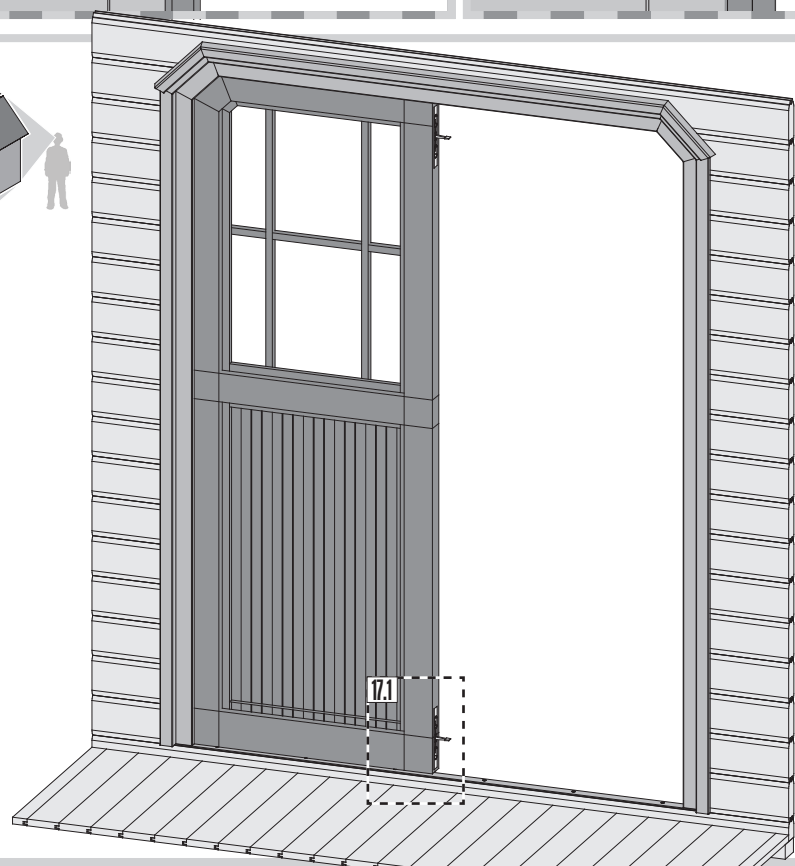
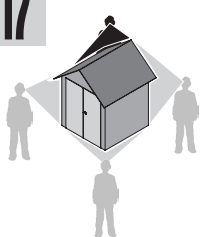

17.1-1

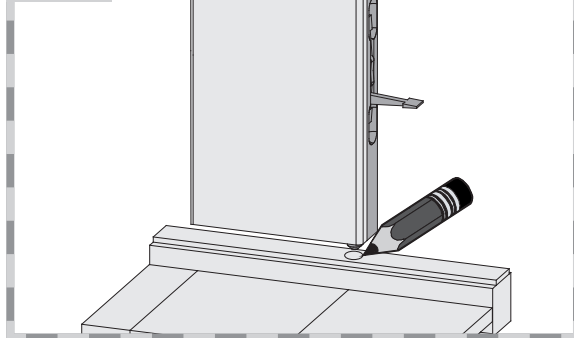

17.1-2

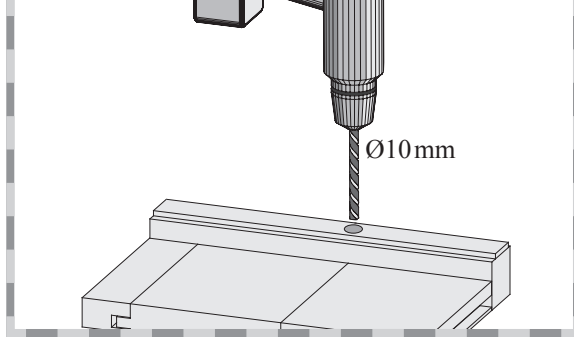

01

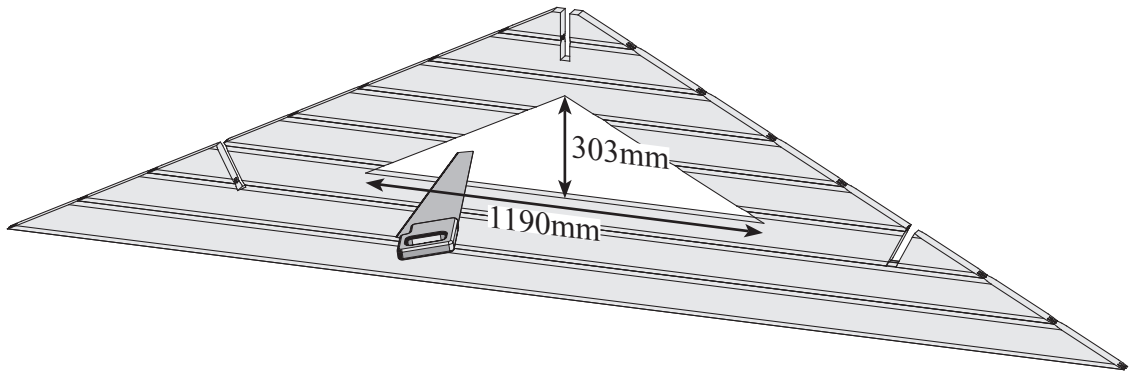

02

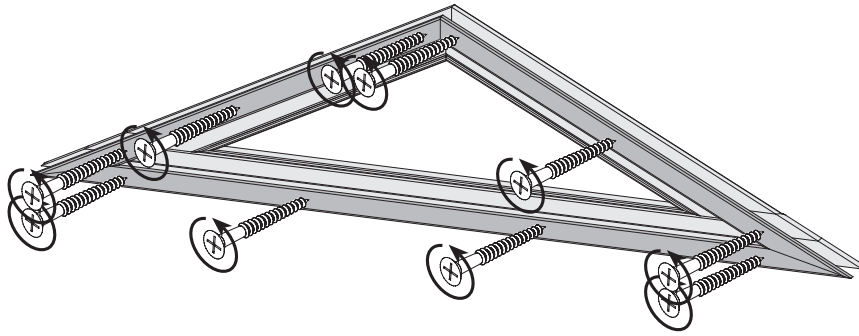

03

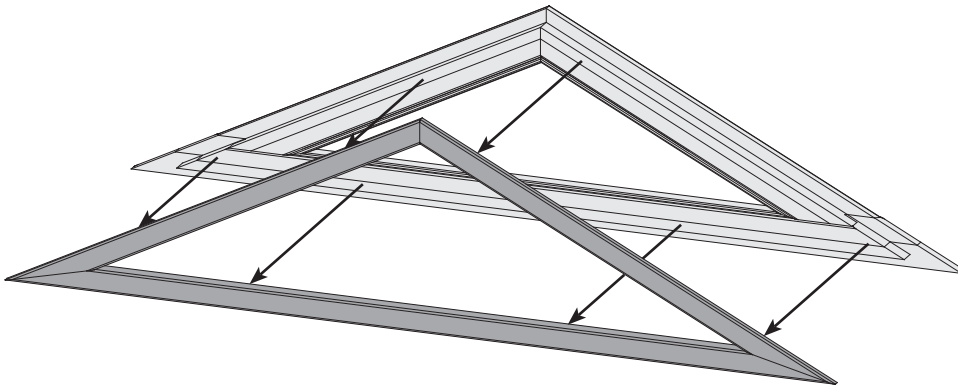

04

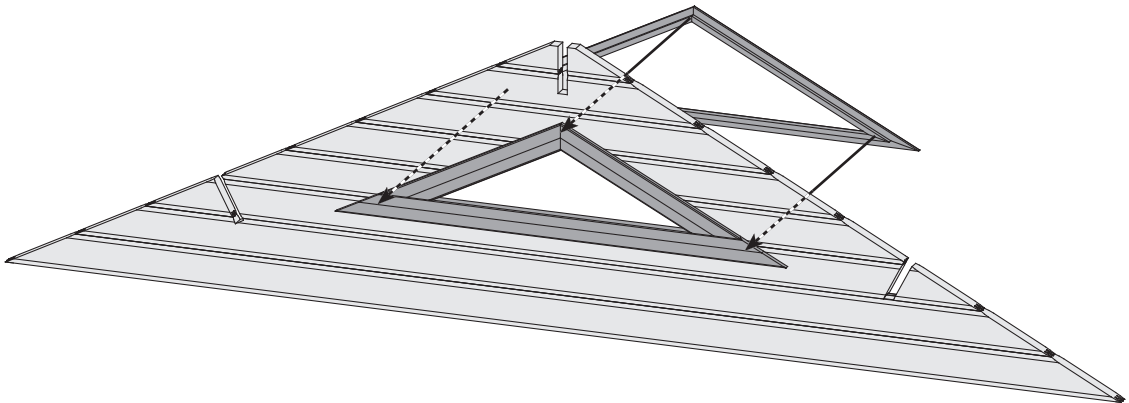

05

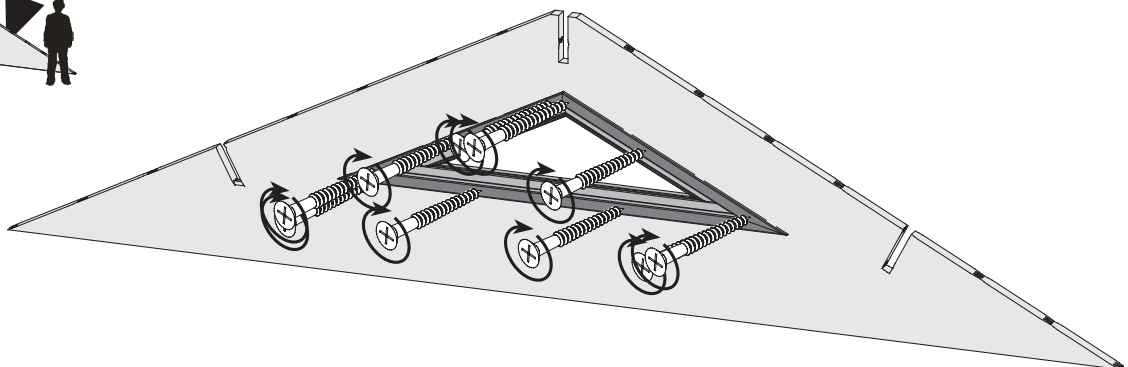

# 13695 16337 21325

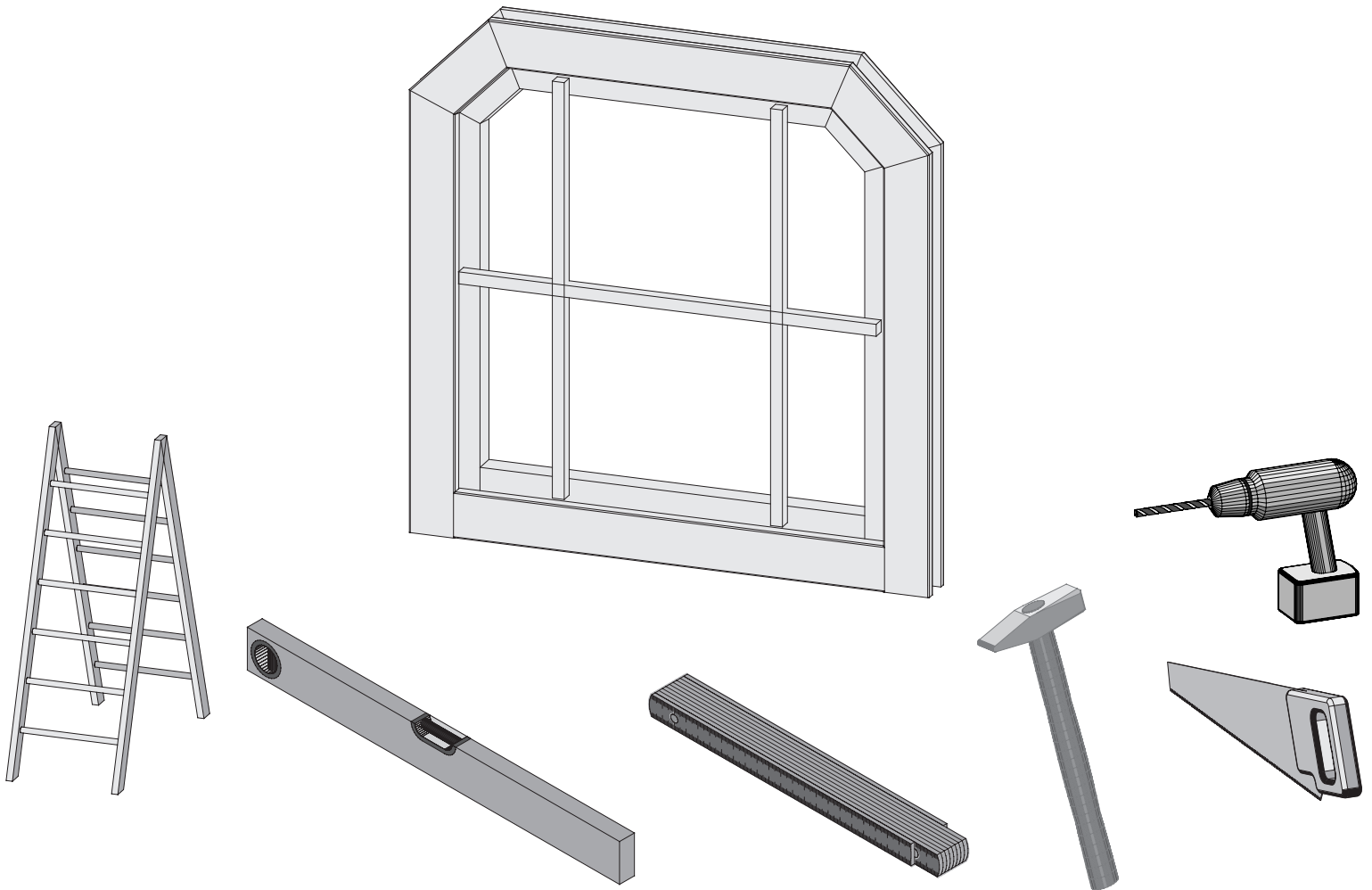

 **Aufbauanleitung**

 **notice de montage**

 **Building Instructions**

 **montagehandleiding**

 **Instrucciones de construcción**

 **Istruzioni per il montaggio**

 **Service-Hotline:+49 421 38693 33**



Vergleichen Sie zuerst die Materialliste mit Ihrem Paketinhalt! Bitte haben Sie Verständnis, dass Beanstandungen nur im nicht aufgebauten Zustand bearbeitet werden können!



Commencez par comparer la liste du matériel avec le contenu de votre paquet! Sachez que nous traitons uniquement les réclamations concernant le matériel à l'état non monté!



First compare the list of materials with your package contents! Please understand that complaints can be processed in the non-built status only!



Vergelijk eerst de lijst van materialen met de inhoud van uw pakket! Reclamaties kunnen alleen in behandeling worden genomen zolang de onderdelen nog niet zijn gemonteerd!



En primer lugar, compare la lista de material con el contenido del paquete. Rogamos entienda que las reclamaciones sólo pueden ser tramitadas antes de montar el objeto!



Confrontate questa distinta materiali prima con il contenuto del pacchetto! Vi preghiamo di comprendere che eventuali reclami possono essere accolti solo prima del montaggio!



**13695 16337**



1 x F1

790 x 790 x 63mm



1 x F2

675 x 675 x 50mm



1 x F3



1 x F4

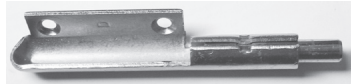

1 x F5

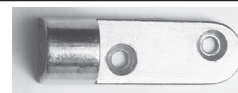

1 x F6



1 x F7



1 x F8



1 x F9



12 x

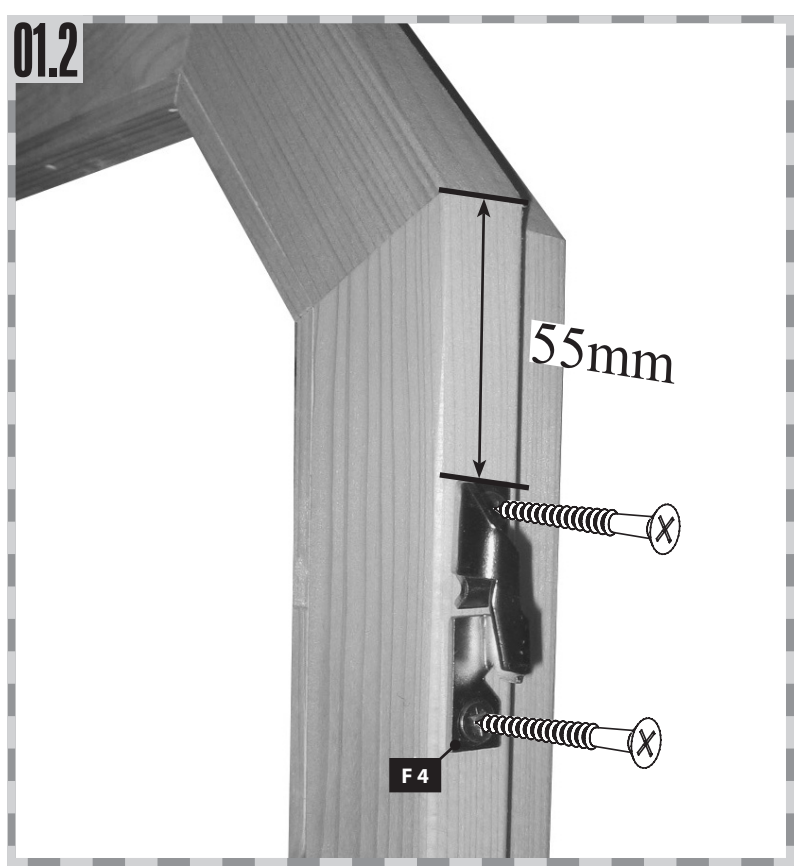
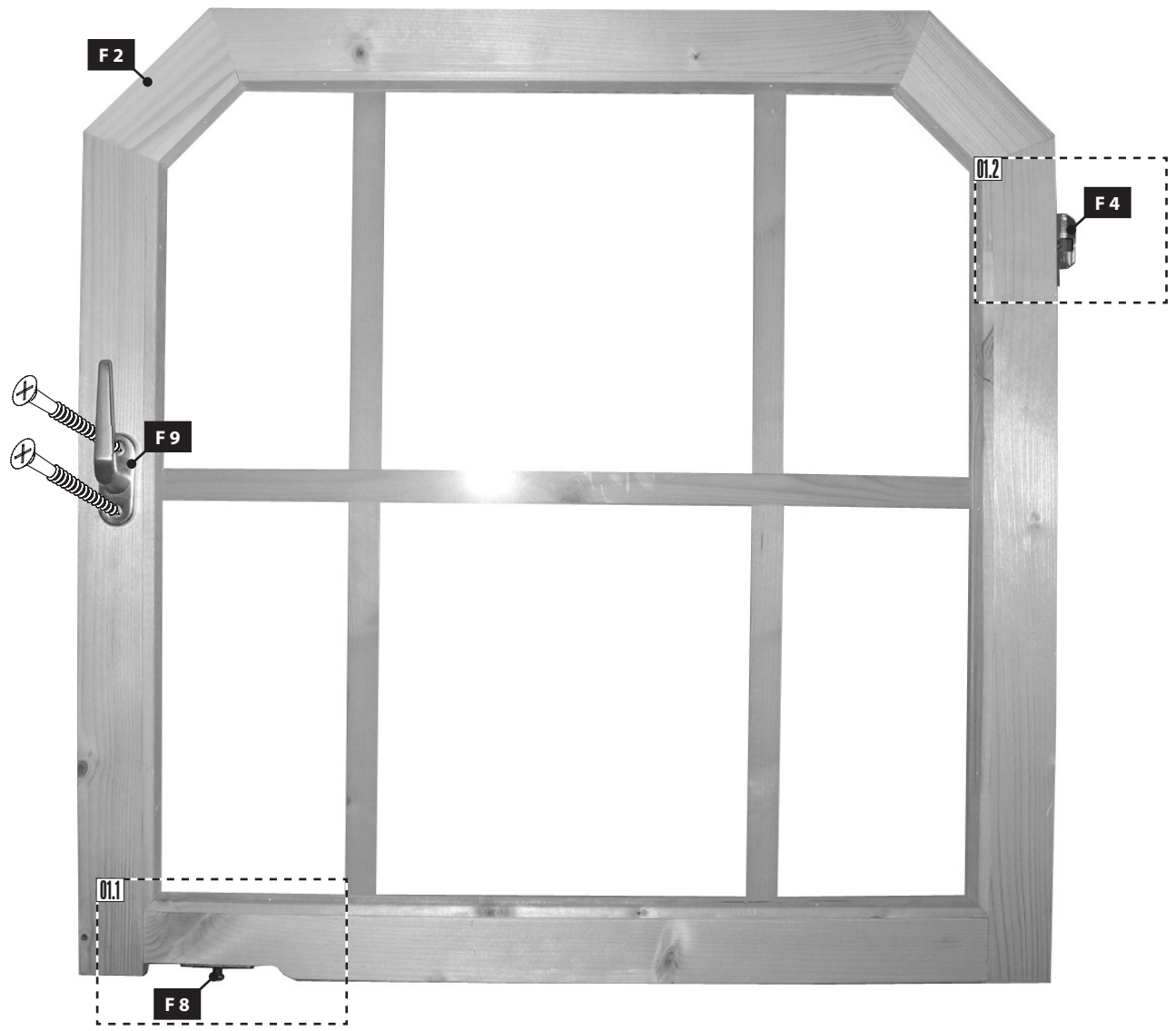

02

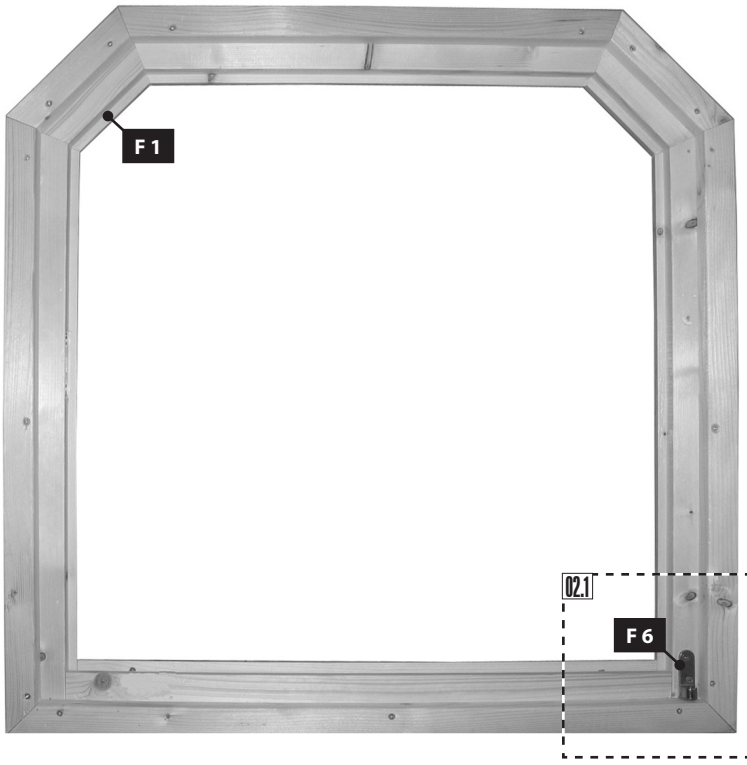

02.1



03

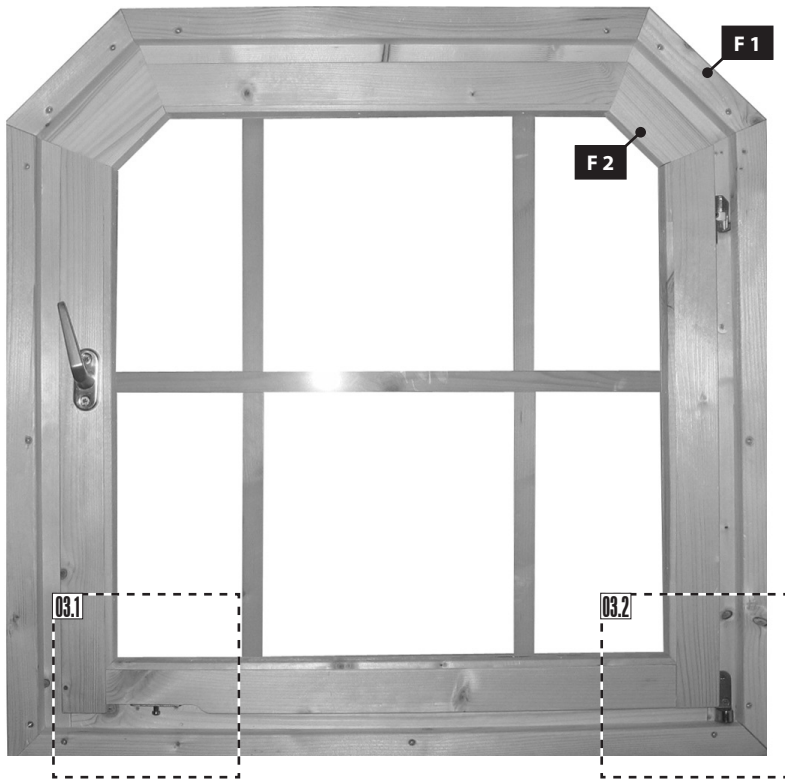

03.1

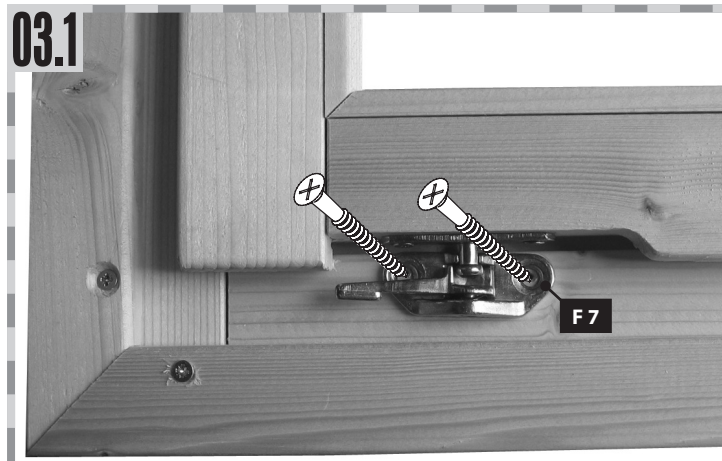

03.2



04

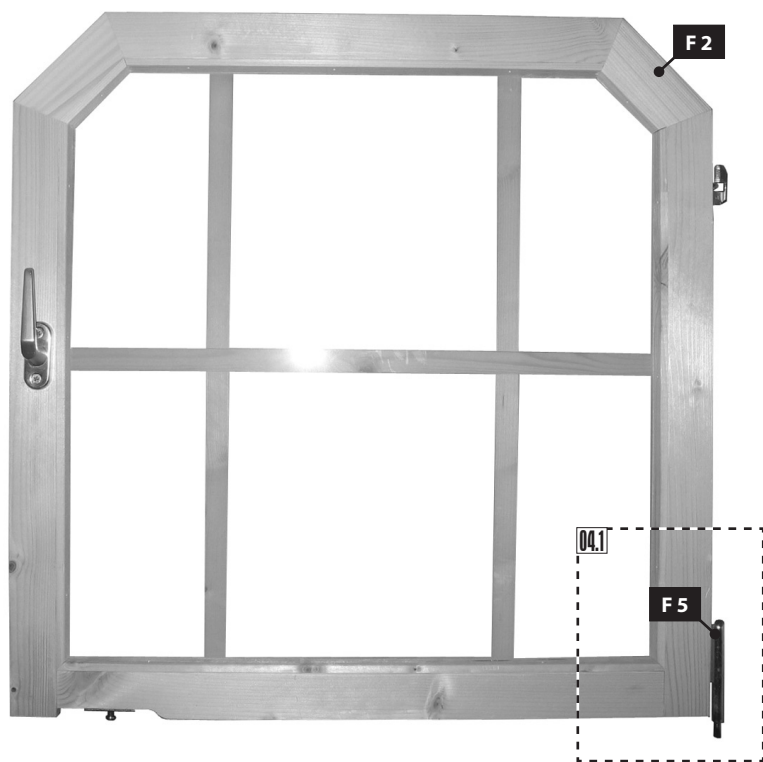

04.1

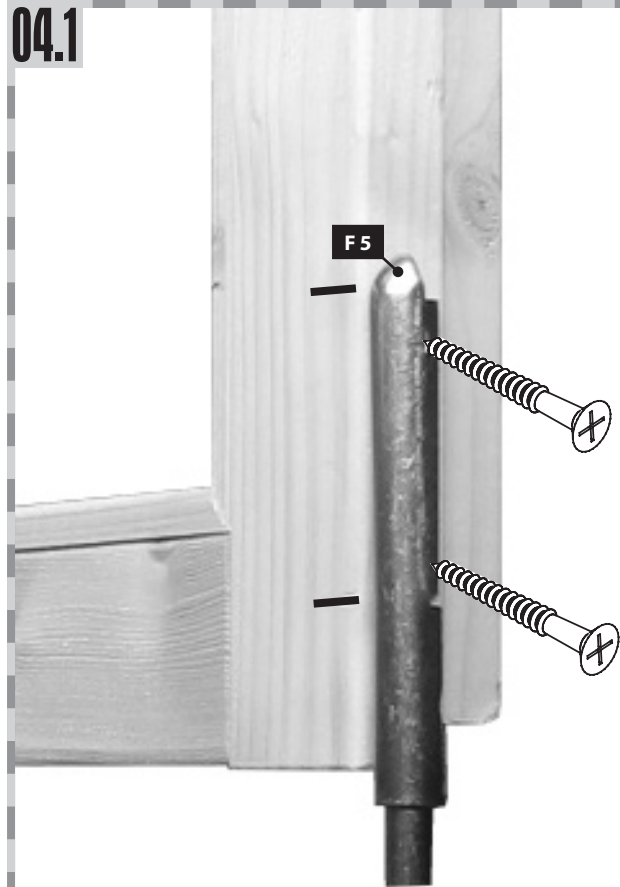

05

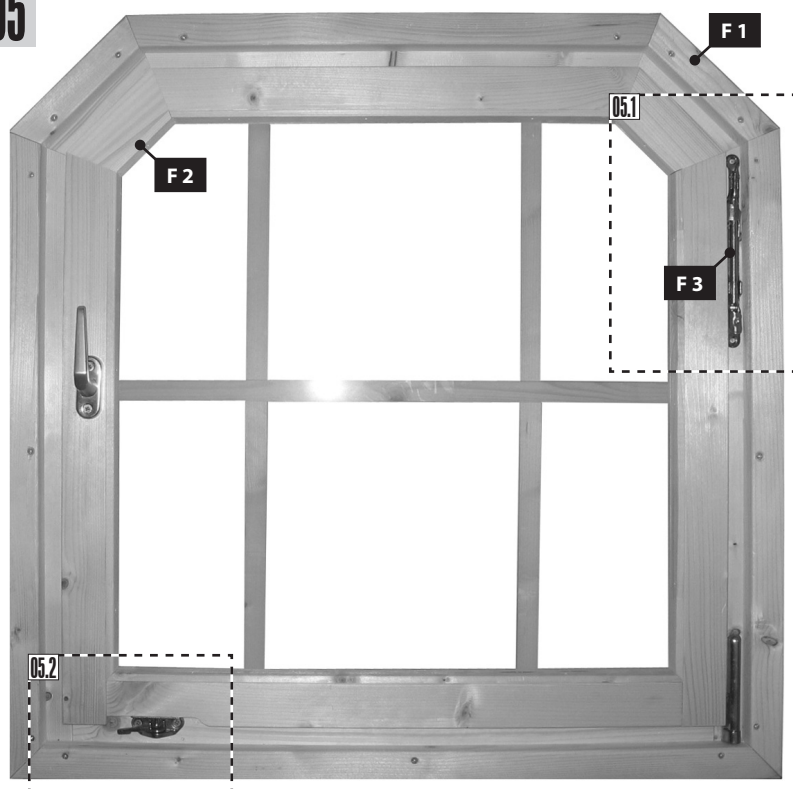



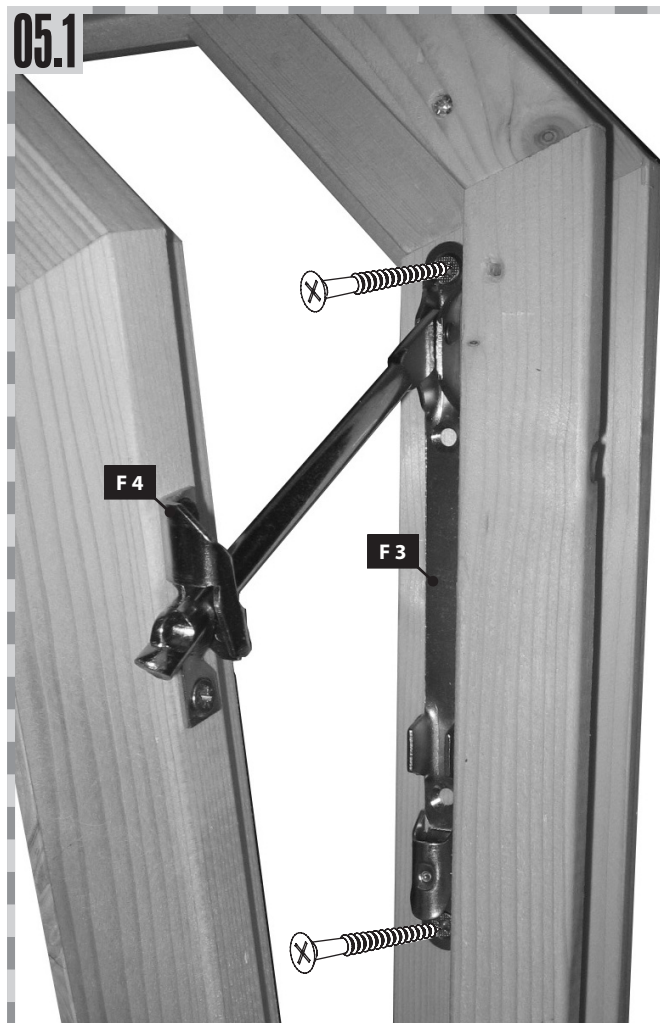

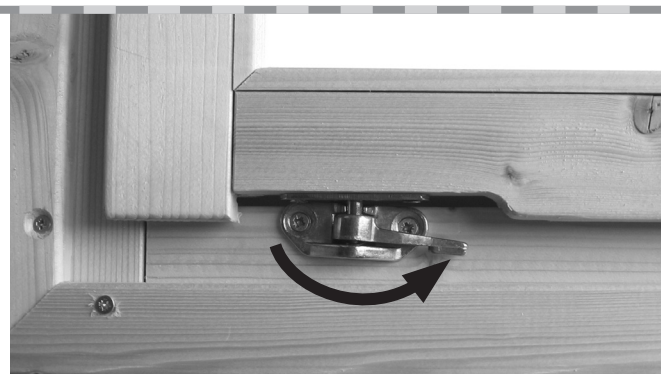

05.1



05.2



-  Führen Sie F3 durch F4 hindurch + Festschrauben
-  Mettez le F3 per F4 + Visser
-  Put F3 through F4 + Screw on
-  Gezette F3 door F4 + Schroef
-  Pase el F3 con F4 + Tornillo encendido
-  Faccia passare il F3 con F4 + Vite sopra

01

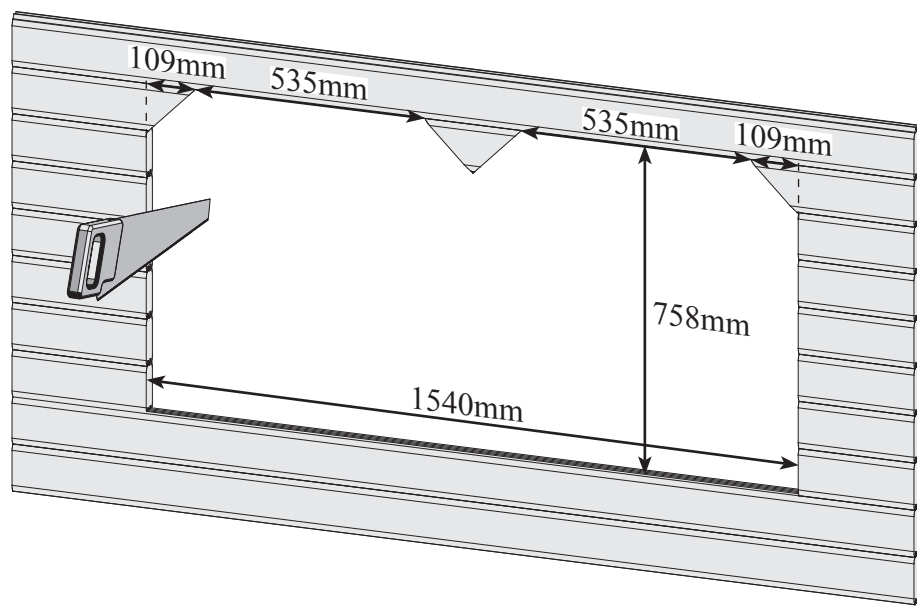

02 2x

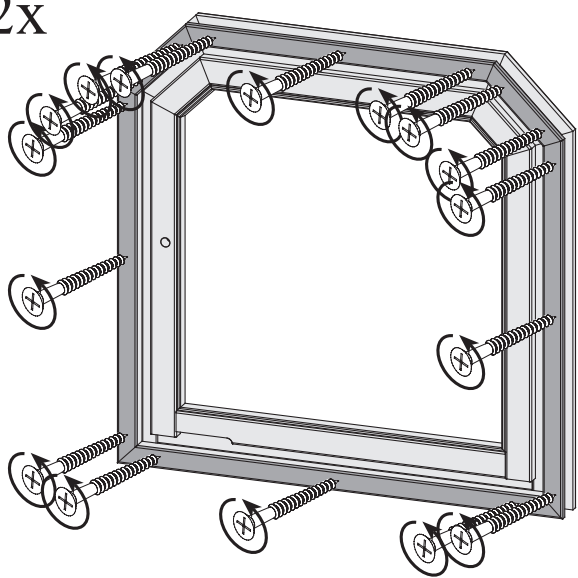

03 2x

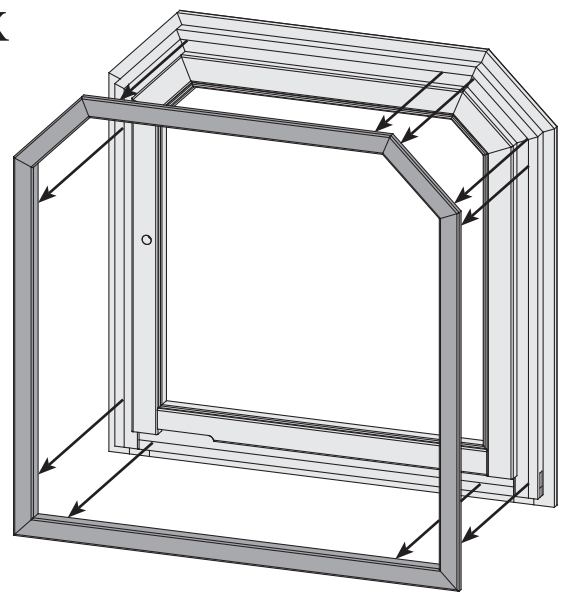

04

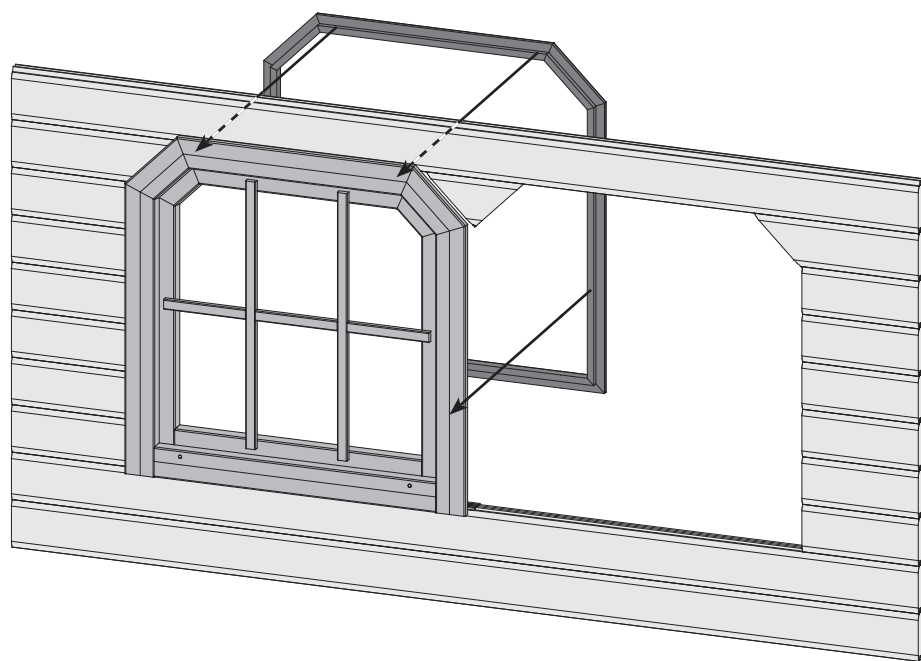

05

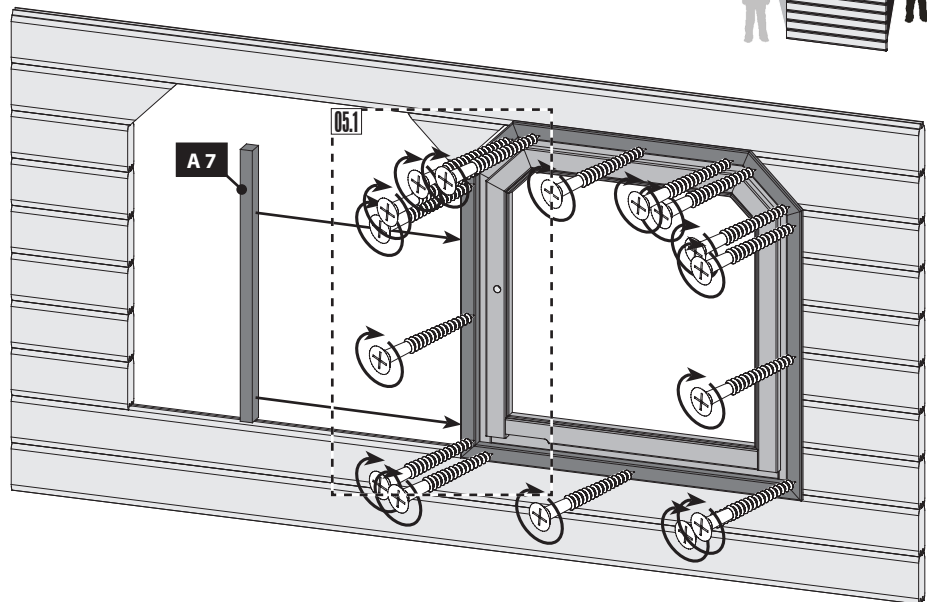

05.1

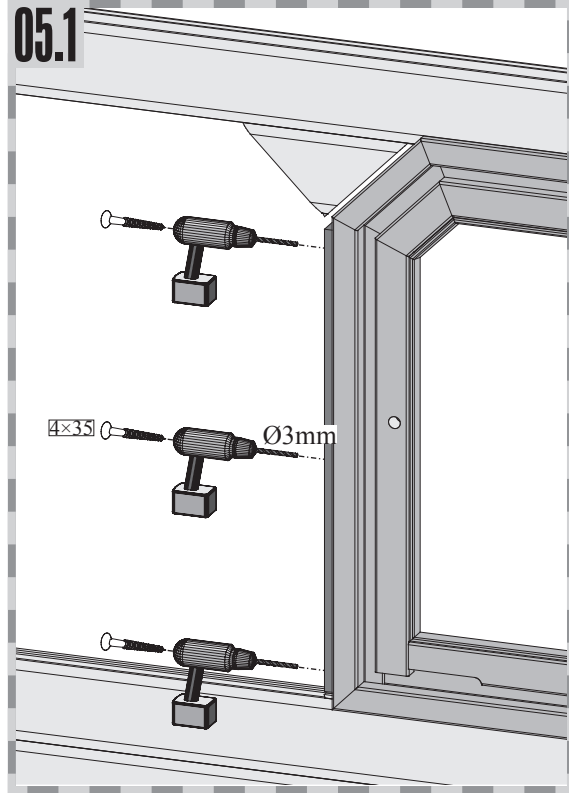

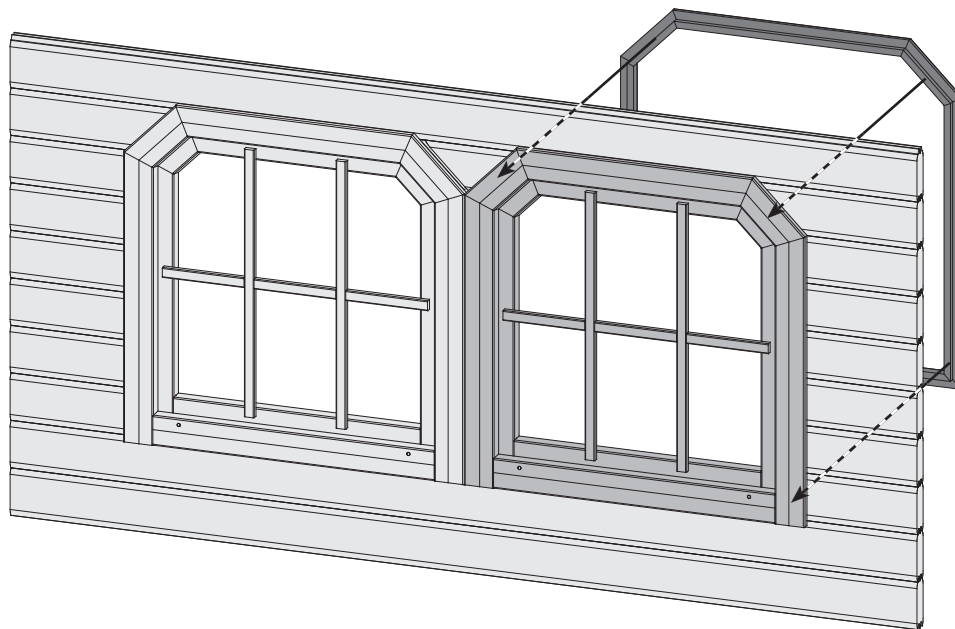

06



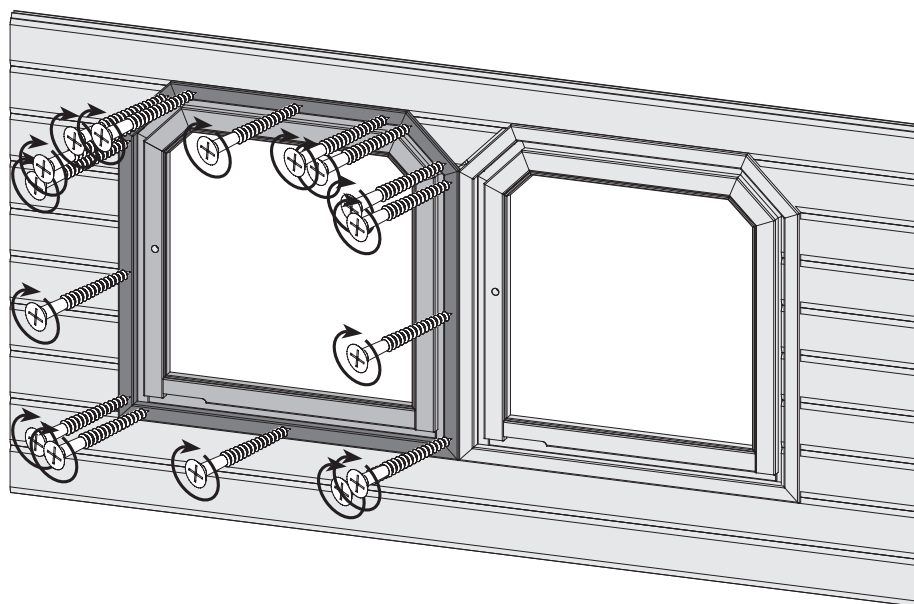

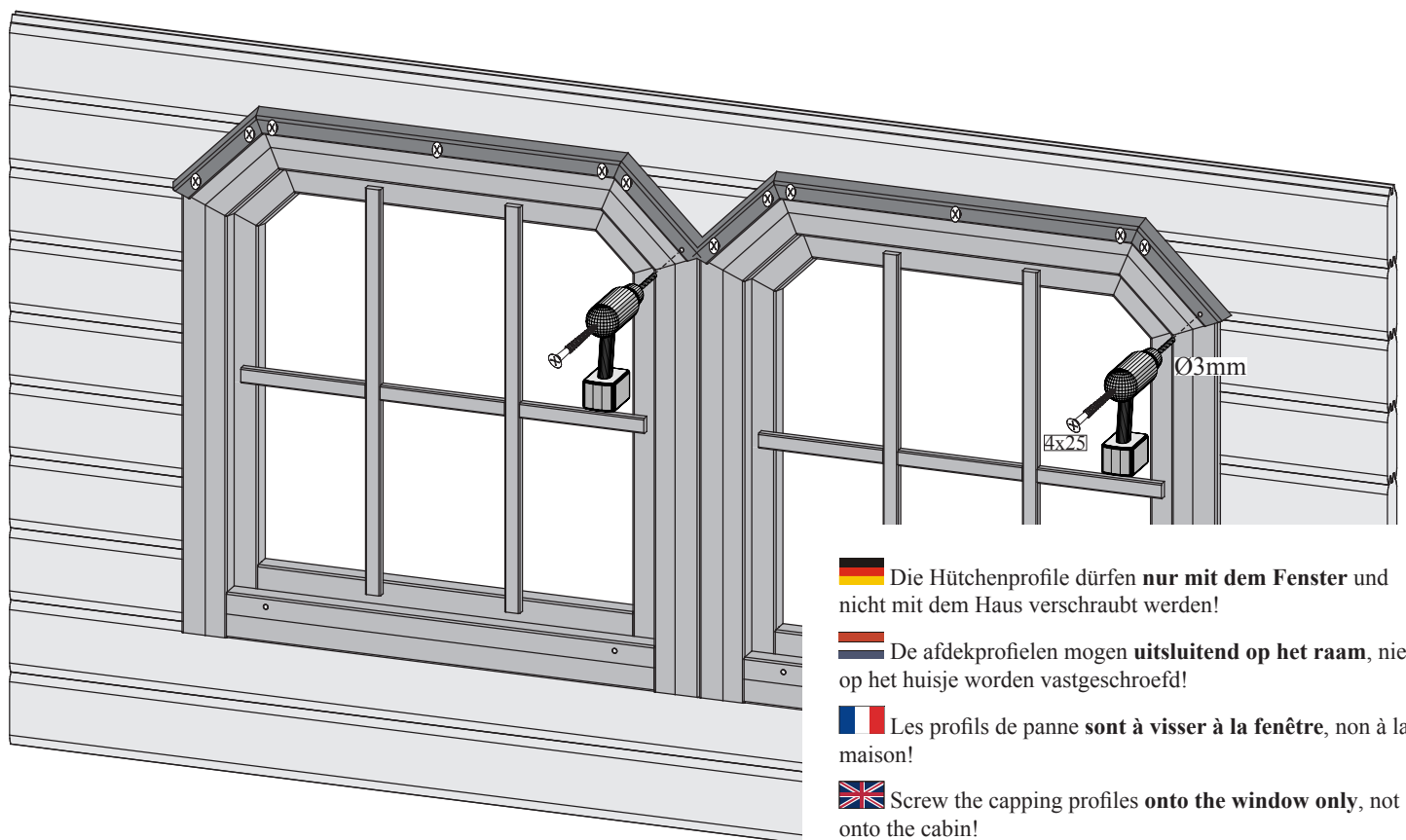
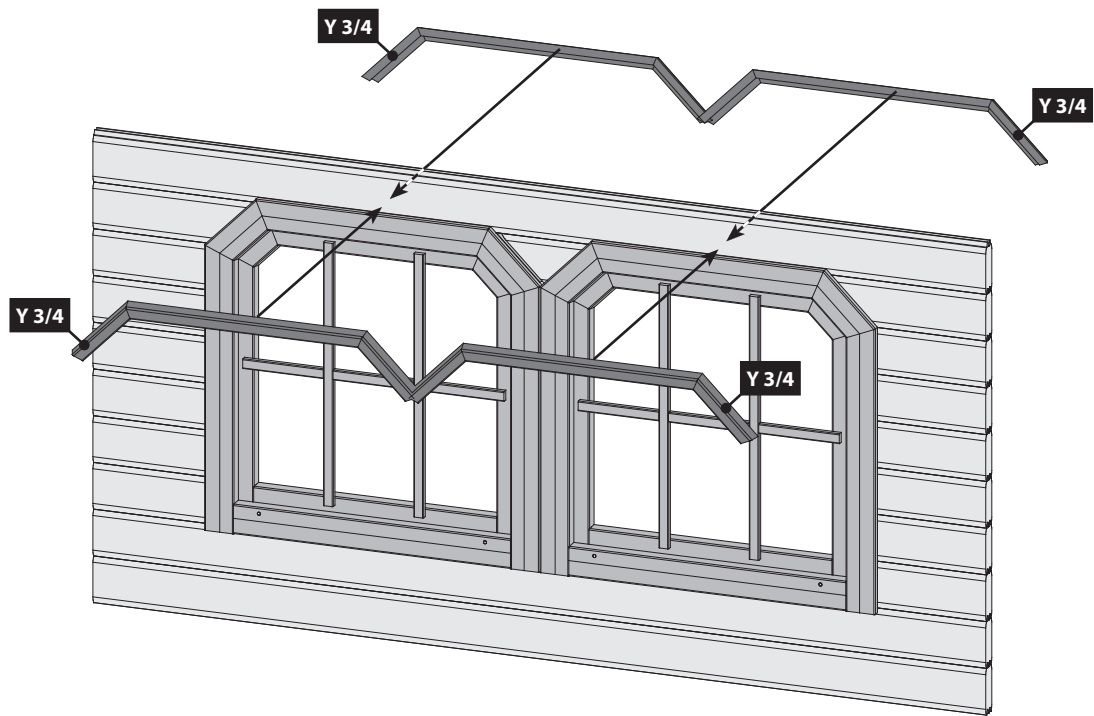
07







 Die Hütchenprofile dürfen **nur mit dem Fenster** und nicht mit dem Haus verschraubt werden!

 De afdekprofielen mogen **uitsluitend op het raam**, niet op het huisje worden vastgeschroefd!

 Les profils de panne **sont à visser à la fenêtre**, non à la maison!

 Screw the capping profiles **onto the window only**, not onto the cabin!

 Los perfiles de sombrerete **sólo se pueden atornillar a la ventana**, no a la caseta!

 I cappellotti possono essere avvitati **solo alla finestra**, non alla casa!